

MASTECH®



CATALOGUE 2023



MEASURING INSTRUMENTS CATALOGUE

CONTENT INDEX

2	WHO IS MGL
3	ABOUT MASTECH
4	FAST SELECTION CHARTS
22	DIGITAL MULTIMETERS
50	DIGITAL CLAMP METERS
66	AC LINE SPLITTERS
69	ELECTRICAL TESTERS
76	CIRCUIT TESTERS
80	CIRCUIT ANALYZERS
83	WIRE & CABLE TESTERS
88	LCR METERS
94	EARTH RESISTANCE
98	INSULATION TESTERS
101	PAT TESTER
103	THERMOMETERS
114	ENVIRONMENTAL METERS
130	ACCESSORIES

WHO IS MGL

We are a global group of companies operating locally. We manufacture test and measurement products for the electrical and automotive industry, from the entry level through high tech products.

Our companies work globally, serving our customers worldwide. This global network delivers a deeper understanding of each individual market, with solutions tailored to the unique requirements of each customer.

With customers over 20 years old, our goal is to be a recognized, honest and fair company. We aim to be the most valued partner for our customers in the research, development, manufacture and supply of innovative, modern and customer-focused technologies.

We have a highly experienced team which is openminded, receptive to new ideas and adaptive to evolving market trends. This solid foundation guarantees that we are well informed and fully equipped to deliver excellent solutions to meet our customers' real needs.



BRANDING CHANNELS

We manufacture electrical test and measurement instruments under our own brands: Mastech, KPS, C-Logic and Power Probe, recognized brands and market leaders in the fields of electrical measurement and automotive. All of our products have a professional positioning based on advanced balanced technology and they are marketed through local distributors throughout the world. We maintain direct and close contact with our distributors, through our offices around the world, and we support them in their business by offering technical advice and an after-sales service for our products.

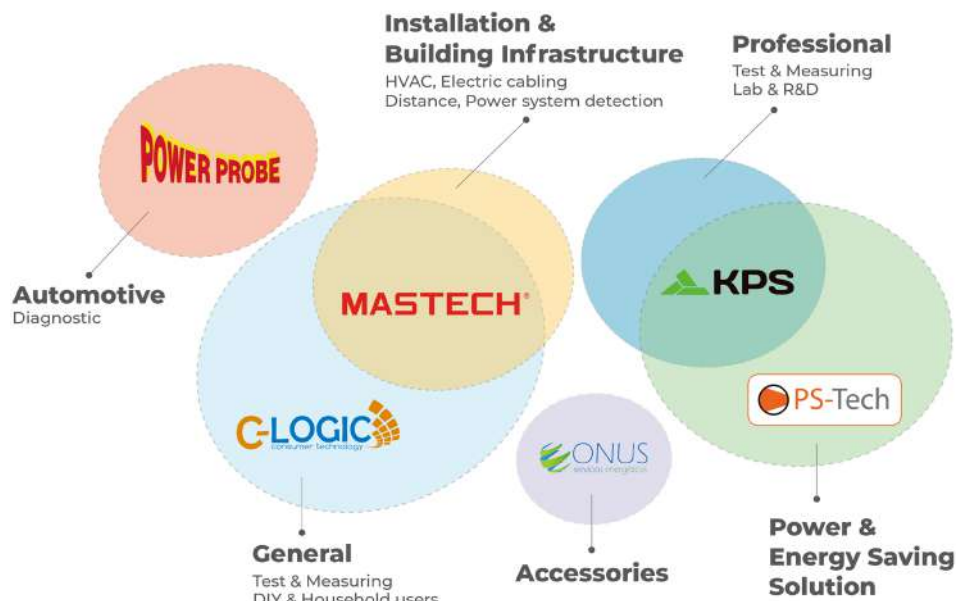

MASTECH®

At MASTECH we focus on providing the highest quality, innovative measuring instruments for the electrical market, along with the best service to our customers.

From digital multimeters and clamp meters to voltage testers, plug testers and all ranges of environmental testers, our product families have been developed to meet the requirements of the construction, DIY and industrial sectors.

Test and measurement equipment:

- I. For industrial environments: we develop a range of measuring instruments with specific features and high precision, ensuring reliability and accuracy.
- II. For the residential sector: MASTECH instruments meet all requirements relating to measuring and testing of electrical values, enabling safety checks on installations and appliances in homes and other buildings.
- III. For environmental measurement, MASTECH offers a wide range of solutions, with measuring instruments for temperature, moisture and wind speed to light, sound, gas and distance.









DIGITAL MULTIMETERS
MANUAL RANGING

CAT II
CAT III
CAT IV



Model	MS8233A	MS8233B	MS8233C	MS8360E	MY70	MY74
Page	23	24	25	26	27	28
Safety Rating	CAT III 600V	CAT III 600V	CAT III 600V	CAT III 600V	CAT III 600V	CAT III 600V
Display Counts	2000	2000	2000	2000	2000	2000
Auto Ranging						
Auto Power Off				•	•	•
True RMS						
DC Voltage	600V	600V	600V	600V	600V	600V
AC Voltage	600V	600V	600V	600V	600V	600V
DC Current	10A	10A	10A	10A	10A	10A
AC Current				10A	10A	10A
Resistance	2MΩ	2MΩ	2MΩ	200MΩ	200MΩ	200MΩ
Capacitance				200μF		100μF
Frequency						20kHz
Duty Cycle						
Type K Temperature			-20~1000°C -4~1832°F			-20~1000°C
Battery Test						
Diode	•	•	•	•	•	•
Continuity	•	•	•	•	•	•
Display Backlight		•	•	•		
Work Light						
Data Hold	•	•	•	•	•	•
NCV		•	•	•		
Inductance				20H		
hFE Transistor					•	•
Dual Display						
MAX						
MAX/MIN						
MAX/MIN/AVG						
Relative Measurement						
Peak Measurement						
DWELL Test						
TACH Test						

DIGITAL MULTIMETERS AUTO RANGING

	NEW						
	CAT II	CAT III	CAT IV				
							
Model	MS820L	MS8233D	MS8233E	MS8238H	MS8239C	MS8250A	MS8250D
Page	29	30	31	32	33	34	35
Safety Rating	CAT II 600V CAT III 300V	CAT II 600V	CAT III 600V	CAT III 600V	CAT III 600V	CAT IV 600V	CAT III 1000V CAT IV 600V
Display Counts	2000	2000	2000	4000	4000	4000	6600
Auto Ranging		•	•	•	•	•	•
Auto Power Off	•	•	•	•	•	•	•
True RMS				•			•
DC Voltage	500V	600V	600V	600V	600V	600V	1000V
AC Voltage	500V	600V	600V	600V	600V	600V	1000V
DC Current	10A	10A	10A	10A	10A	10A	10A
AC Current		10A	10A	10A	10A	10A	10A
Resistance	200MΩ	20MΩ	20MΩ	40MΩ	40MΩ	40MΩ	66MΩ
Capacitance					100μF	100μF	66mF
Frequency		20kHz			10kHz	5MHz	66MHz
Duty Cycle					•	•	•
Type K Temperature			-20~1000°C -4~1832°F	-20~1000°C -4~1832°F	-20~1000°C -4~1832°F		
Battery Test				•			
Diode		•	•	•	•	•	•
Continuity	•	•	•	•	•	•	•
Display Backlight		•	•		•	•	•
Work Light							
Data Hold	•	•	•	•	•	•	•
NCV		•	•	•		•	•
Inductance							
hFE Transistor							
Dual Display							•
MAX		•	•				
MAX/MIN							•
MAX/MIN/AVG							
Relative Measurement						•	•
Peak Measurement							
Low Pass Filter							
AC/DC Current (For Clamp)							
Low Impedance							
Bar Graph							
Interface					Wireless		USB





AUTO RANGING

CAT II
CAT III
CAT IV



Model	MS8251A	MS8251B	MS8301D	MS8340A	MS8360F	MS8360G	MS8361D
Page	36	37	38	39	40	41	42
Safety Rating	CAT III 1000V CAT IV 600V	CAT III 1000V CAT IV 600V	CAT III 600V	CAT III 1000V	CAT III 600V	CAT III 600V	CAT III 600V
Display Counts	6600	6600	6000	6000	4000	4000	4000
Auto Ranging	•	•	•	•	•	•	•
Auto Power Off	•	•	•	•	•	•	•
True RMS		•					•
DC Voltage	1000V	1000V	600V	1000V	600V	600V	600V
AC Voltage	1000V	1000V	600V	750V	600V	600V	600V
DC Current	10A	10A		10A	10A	10A	10A
AC Current	10A	10A		10A	10A	10A	10A
Resistance	66MΩ	66MΩ	10MΩ	60MΩ	40MΩ	40MΩ	40MΩ
Capacitance	66mF	66mF		400μF	200μF	4000μF	99.99mF
Frequency	66MHz	10kHz	3kHz	10MHz	10MHz	10MHz	10kHz
Duty Cycle	•	•	•	•	•	•	•
Type K Temperature	0~1000°C 32~1832°F	0~1000°C 32~1832°F		-10~700°C 14~1292°F		-20~1000°C -4~1832°F	
Battery Test							
Diode	•	•		•	•	•	•
Continuity	•	•	•	•	•	•	•
Display Backlight	•	•	•	•	•	•	•
Work Light							
Data Hold	•	•	•	•	•	•	•
NCV	•	•	•		•	•	•
Inductance							
hFE Transistor							•
Dual Display	•	•	•				
MAX							
MAX/MIN	•	•	•	•		•	
MAX/MIN/AVG							
Relative Measurement	•	•		•	•	•	•
Peak Measurement							
Low Pass Filter				•			
Sound & Light Warning							
Low Impedance		•					
Bar Graph		•				•	
Interface							Wireless

DIGITAL MULTIMETERS POCKET/PEN TYPE







					
Model	M300	M320	MS8333A	MS8211	MS8212A
Page	43	44	45	46	47
Safety Rating	CAT II 600V CAT III 300V	CAT II 600V CAT III 300V	CAT III 600V	CAT II 600V	CAT III 600V
Display Counts	2000	4000	6000	2000	2000
Auto Ranging		•	•	•	•
Auto Power Off		•	•	•	•
True RMS			•		
DC Voltage	600V	600V	600V	600V	600V
AC Voltage	600V	600V	600V	600V	600V
DC Current	200mA	400mA	600mA		200mA
AC Current		400mA	600mA		200mA
Resistance	20MΩ	40MΩ	60MΩ	20MΩ	20MΩ
Capacitance		100μF	600μF		
Frequency		100kHz	10kHz		
Duty Cycle			•		
Battery Test			•		
Diode	•	•	•	•	•
Continuity	•	•	•	•	•
Display Backlight			•		
Work Light					
Data Hold		•	•	•	•
NCV			•	•	•
Inductance					
hFE Transistor					
Dual Display					
MAX				•	•
MAX/MIN					
MAX/MIN/AVG					
Relative Measurement					
Peak Measurement					
DWELL Test					
TACH Test					
Logic Level Test					•
Retractable Tip				•	
Double Molding					•

**DIGITAL MULTIMETERS
SPECIAL APPLICATION**

 CAT II
 CAT III
 CAT IV





Model	MS5208	MS8229
Page	48	49
Safety Rating	CAT III 1000V CAT IV 600V	CAT III 600V
Display Counts	6600	4000
Auto Ranging	•	•
Auto Power Off	•	•
True RMS	•	
DC/AC Voltage	1000V/750V	1000V/750V
DC/AC Current	400mA/400mA	10A/10A
Resistance	66MΩ	40MΩ
Capacitance	66mF	100μF
Frequency	10kHz	200kHz
Duty Cycle	•	
Diode	•	•
Type K Temperature	-30~1300°C / -22~2372°F	-20~1000°C / -4~1832°F
Continuity	•	•
Display Backlight	•	•
Data Hold	•	•
NCV		
hFE Transistor		
MAX		
MAX/MIN		
MAX/MIN/AVG	•	
Relative Measurement	•	
Low Pass Filter	•	
Insulation Test	1000V/2GΩ	
DAR/PI	•	
Relative Humidity		20~95%
Sound level		40~100dB
Luminosity		4000/40000Lux
Environment Temperature		0~40°C/32~104°F
Cable Check		
Sound & Light Warning		•
Data Logging	100 Groups	
Interface		
DWELL/TACH Test		

DIGITAL CLAMP METERS AC CURRENT

							
	CAT II CAT III CAT IV						
Model	M266	MS2001	MS2001C	MS2009A	MS2009C	MS2025C	MS2028A
Page	51	52	53	54	55	56	57
Safety Rating	CAT II 1000V CAT III 600V	CAT II 1000V CAT III 600V	CAT II 1000V CAT III 600V	CAT III 600V	CAT III 600V	CAT III 1000V CAT IV 600V	CAT III 600V
Display Counts	2000	2000	2000	2000	6000	6600	2000
Jaw Size	Φ50mm 2.0"	Φ42mm 1.7"	Φ42mm 1.7"	Φ26mm 1.0"	Φ26mm 1.0"	Φ40mm 1.6"	Φ26mm 1.0"
Auto Ranging				•	•	•	•
Auto Power Off				•	•	•	•
True RMS						•	•
DC Voltage	1000V	1000V	1000V	600V	600V	1000V	600V
AC Voltage	750V	750V	750V	600V	600V	750V	600V
DC Current							
AC Current	1000A	1000A	1000A	600A	600A	1000A	600A
Resistance	20kΩ	2000Ω	2000Ω	20MΩ	60MΩ	66MΩ	20MΩ
Capacitance					60mF	66mF	
Frequency					1kHz	66MHz	
Duty Cycle					•	•	
Type K Temperature			-40~750°C		-20~1000°C -4~1832°F	-20~1000°C -4~1832°F	
Diode		•		•	•	•	•
Continuity	•	•	•	•	•	•	•
Display Backlight		•	•	•	•	•	•
Work Light				•	•	•	
Data Hold	•	•	•	•	•	•	•
NCV				•	•	•	
MAX/MIN				MAX		•	Max
Relative Measurement						•	
Bar Graph						•	
Insulation Test	2000MΩ						
DC Current (From Plug)							
Low Pass Filter							
Low Impedance							
Dual Display						•	
Infrared Temperature							
Interface							



DIGITAL CLAMP METERS AC CURRENT

DIGITAL CLAMP METERS AC/DC CURRENT

				
CAT II CAT III CAT IV				
Model	MS2030	MS2033A	MS2109A	MS2125A
Page	58	59	60	61
Safety Rating	CAT III 600V	CAT III 600V	CAT III 600V	CAT III 1000V CAT IV 600
Display Counts	2000	6000	6000	6000
Jaw Size	Φ28mm 1.1"	Φ26mm 1.0"	Φ26mm 1.0"	Φ40mm 1.6"
Auto Ranging		•	•	•
Auto Power Off		•	•	•
True RMS				•
DC Voltage	600V	600V	600V	1000V
AC Voltage	600V	600V	600V	750V
DC Current			600A	1000A
AC Current	400A	600A	600A	1000A
Resistance	2kΩ	10MΩ	60MΩ	60MΩ
Capacitance			MS2109A	100mF
Frequency		3kHz	10MHz	1000Hz
Duty Cycle		•	•	•
Type K Temperature			-20~1000°C -4~1832°F	
Diode	•		•	•
Continuity	•	•	•	•
Display Backlight		•	•	•
Work Light			•	•
Data Hold	•	•	•	•
NCV			•	•
MAX/MIN		•	•	•
Relative Measurement			•	•
Bar Graph				
Insulation Test				
DC Current (From Plug)				
Low Pass Filter				
Low Impedance				
Dual Display		•		
Infrared Temperature				
Interface				

DIGITAL CLAMP METERS LEAKGE

DIGITAL CLAMP METERS POWER

			
CAT II CAT III CAT IV			
Model	MS2006B	MS2016A	MS2225A
Page	62	63	64
Safety Rating	CAT III 600V	CAT III 600V	CAT III 1000V
Display Counts	2000	4000	6000
Jaw Size	Φ31mm 1.2"	Ø30mm 1.2"	Φ40mm 1.6"
Auto Ranging		•	•
Auto Power Off	•	•	•
True RMS		•	•
DC Voltage		600V	1000V
AC Voltage		600V	750V
DC Current			
AC Current	60A	150A	1000A
Resistance		40MΩ	60MΩ
Capacitance		40mF	100mF
Frequency			10kHz
Duty Cycle			•
Type K Temperature		-20~1000°C -4~1832°F	
Diode		•	•
Continuity		•	•
Display Backlight			•
Work Light			•
Data Hold	•	•	•
NCV			•
MAX/MIN		•	•
Relative Measurement			•
Bar Graph			
Active Power			750kW
Apparent Power			750kVA
Reactive Power			750kVAr
Power Factor			0.3~1
Active Energy			
Harmonic Measurement			45~65Hz
Data Logging			
Interface			Wireless



DIGITAL CLAMP METERS
SPECIAL APPLICATION

CAT II
CAT III
CAT IV









Model	MS2601
Page	65
Safety Rating	CAT III 600V
Display Counts	6000
Jaw Size	Φ12mm 0.5"
Auto Ranging	•
Auto Power Off	•
True RMS	
DC Voltage	600V
AC Voltage	600V
DC Current	
AC Current	200A
Inrush Current	
Resistance	60MΩ
Capacitance	60mF
Frequency	60MHz
Duty Cycle	
Type K Temperature	-20~400°C -4~750°F
Diode	•
Continuity	•
Display Backlight	•
Work Light	•
Data Hold	•
NCV	•
MAX/MIN	
Relative Measurement	
Bar Graph	
Insulation Test	
DC Current (From Plug)	1000μA
Low Pass Filter	
Low Impedance	•
Dual Display	
Infrared Temperature	
Interface	



LINE SPLITTERS

		
	<p>CAT II CAT III CAT IV</p>	
Model	MS922D	MS922E
Page	67	68
Safety Rating	CAT II 600V	CAT II 600V
AC Voltage	250V	250V
AC Current	15A	15A
Frequency	50~60Hz	50~60Hz
Feature	<ul style="list-style-type: none"> -Allows for easy AC Current measurements -Using a Clamp meter on 2 or 3 Wire Power Cords -Provides the Ability to Safely Measure Current without the need to cut or separate conductors -Separates the Hot/Live conductor from the Neutral and Ground -Voltage check sockets for easy power calculations 	
Style	EU	UK



ELECTRICAL TESTERS

						
	<p>CAT II CAT III CAT IV</p>					
Model	MS8900	MS8900A	MS8902A	MS8902B	MS8922A	MS8922B
Page	70	71	72	73	74	75
Safety Rating	CAT II 1000V CAT III 600V	CAT II 1000V CAT III 600V	CAT II 1000V CAT III 600V	CAT II 1000V CAT III 600V	CAT III 600V	CAT III 400V
Non Contact Voltage	100~240V	90~1000V	12~1000V	20~1000V		
Contact Voltage					400V	400V
Frequency	50~60Hz	50~60Hz	50~500Hz	50~500Hz	50~60Hz	50~60Hz
Metal Detecting				<20mm		
RCD Test						•
Work Light						
Sound & Light	•	•	•	•		
Auto Power Off			•	•		
Sensitivity adjustment			•	•		





CIRCUIT TESTERS

			
	<p>CAT II CAT III CAT IV</p>		
Model	MS5902RT	MS5905RT	MS6860
Page	77	78	79
Safety Rating	CAT II 600V	CAT II 600V	CAT II 230V
AC Voltage	230V/120V	230V	230V
Socket Test	•	•	•
GFCI Test	TF type	TF type	
RCD Test			
Work Light	•		
NCV		•	
Buzzer & LED Instruction	•	•	•





CIRCUIT ANALYZERS

		
	<p>CAT II CAT III CAT IV</p>	
Model	MS5900	MS5901
Page	81	82
Safety Rating	CAT III 600V	CAT III 600V
AC Voltage	400V	400V
Frequency	400Hz	400Hz
Motor & Phase Rotation Indicator	•	•
Voltage Drop Current		
Impedance measurement		
GFCI Test		
RCD Test		
Data Hold		
Backlight		



WIRE & CABLE TESTERS

				
CAT II CAT III CAT IV				
Model	MS6810	MS6811	MS6813	MS6818
Page	84	85	86	87
Safety Rating				CAT III 300V
Auto Ranging				•
DC Voltage				12~400V
AC Voltage				12~400V
Frequency			300kHz	125kHz
Low Battery Indicator		•		
Sensitivity Adjustable			•	•
Electric Wire			•	•
Coaxial Cable (BNC)	•		•	
Network Cable	•	•	•	
Telephone Wire			•	
Backlight				•
Worklight				•
Sound & light instructions			•	•



LCR METERS

					
Model	MS5308	MS6013	MS8910	MS8911	MY6243
Page	89	90	91	92	93
Auto Ranging			•	•	
Auto Power Off			•	•	
Resistance	2Ω/200MΩ		300Ω/30MΩ	60Ω/20MΩ	
Capacitance	2000pF/2000μF	200pF/20mF	3nF/30mF	600pF/6mF	2nF/200μF
Inductance	2000μH~2000H			600μH/200H	2mH~2H
Diode			•		
Continuity Buzzer			•		
Auto Scanning			•	•	
Zero Adjustment		•			
LCR/DCR	•			•	
Data Hold	•		•	•	
Backlight	•				
Relative Measurement	•				
Interface	RS232				

EARTH RESISTANCE

	<p>CAT II CAT III CAT IV</p> 		
Model	MS2301	MS2302	MS2308
Page	95	96	97
Safety Rating	CAT III 150V	CAT III 300V	
Resistance	1200Ω	4000Ω	20kΩ
Measurement Voltage		AC 200V	AC 20V/48V DC 20V
Sensing & Inducing Current Transformer			•
Back light		•	•
Interface			USB

INSULATION TESTERS

	<p>CAT II CAT III CAT IV</p> 	
Model	MS5201	MS5215
Page	99	100
Safety Rating	CAT II 1000V CAT III 600V	CAT III 1000V CAT IV 600V
Insulation Resistance	0.01MΩ~2GΩ	0.01MΩ~5TΩ
Output Voltage	1kV DC	5kV DC
Leakage Current test		1nA~3mA
Continuity Test		
Measurement Voltage	DC 1000V AC 700V	DC 1000V AC 750V
Short Current	1.8mA	3mA
Temperature Test		-10~70°C
Back Light		•
Interface		USB

DIGITAL THERMOMETERS



Model	MS6500	MS6511	MS6512	MS6513	MS6514
Page	104	105	106	107	108
Thermocouple Type	K	K.J.T.E	K.J.T.E	K.J.T.E. R.S.N	K.J.T.E. R.S.N
Temperature	-50~750°C -58~1382°F	-200~1372°C -328~2501°F	-200~1372°C -328~2501°F	-200~1372°C -328~2501°F	-200~1372°C -328~2501°F
Injection Method	Single	Single	Dual	Single	Dual
Channel		TC	T1/T2/T1-T2	TC	T1/T2/T1-T2
Relative Humidity					
Update Rate	500ms				
Clock					
MAX/MIN/AVG/DIF		•	•	•	•
Date Logging				1000 groups	1000 groups
Backlight					
Date Hold	•	•	•	•	•
Interface				USB	USB

INFRARED THERMOMETERS



Model	MS6522A	MS6522B	MS6531B	MS6531C	MS6541
Page	109	110	111	112	113
Color Display			•	•	•
IRT Temperature	-20~300°C -4~572°F	-20~500°C -4~932°F	-40~800°C -40~1472°F	-40~800°C -40~1472°F	-50~760°C -58~1400°F
Type K Temperature				-40~1080°C -40~1976°F	-50~300°C -58~572°F
Distance to Spot(D:S)	10:1	10:1	12:1	12:1	30:1
Emissivity	0.95	0.95	0.1~0.99	0.1~0.99	0.1~0.99
MAX/MIN/AVG/DIF	MAX/MIN/AVG	MAX/MIN/AVG	•	•	•
Data Logging				20 groups	100 groups
Backlight	•	•	•	•	•
Data hold	•	•	•	•	•

SOUND METERS



Model	MS6700	MS6701	MS6708
Page	115	116	117
Display	2000	2000	2000
Auto Ranging	•	•	•
Auto Power Off	•	•	•
Sound Level	30~130dB	30~130dB	30~130dB
Dynamic	50dB	50dB	50dB
Frequency	31.5Hz~8kHz	31.5Hz~8kHz	30Hz~8kHz
A/C Weighting	•	•	•
Data Logging		16000	
Data Hold			•
Date/Time	•	•	
Backlight	•	•	•
MAX	•	•	•
AC adapter	•	•	
AC/DC Signal output	•	•	
Interface		USB	

ANEMOMETERS



Model	MS6252A	MS6252B
Page	118	119
m/s	0.8~40 m/s	0.8~40 m/s
km/h	2.88~144 km/h	2.88~144 km/h
ft/s	2.62~131.2 ft/s	2.62~131.2 ft/s
Knots	1.6~77.70 Knots	1.6~77.70 Knots
mile/h	1.8~90.00 mile/h	1.8~90.00 mile/h
ft/m	157.5~7874 ft/m	157.5~7874 ft/m
Temperature		-10~60°C
Relative Humidity		20~80%RH
Ambient		•
Dew point		•
Wet Bulb		•
Interface		USB

LIGHT METERS



Model	MS6610	MS6612	MS6612B
Page	120	121	122
Auto Ranging		•	•
Auto Power Off		•	•
Display Counts	2000	2000	2000
Ranging	0~50000Lux	0~200000Lux 0~20000FC	0~200000Lux 0~20000FC 0~999900CD
Unit Selection	Lux	Lux/FC	Lux/FC/CD
Relative		•	•
Peak		•	•
MAX/MIN		•	•
Data Hold	•	•	•
Bar Graph		•	•
LED light source			•
Interface			

TACHOMETERS



Model	MS6208A	MS6208B
Page	123	124
Contact	50~19999	
Measurement	50~19999RPM	50~99999RPM (Non-Contact)
Measuring Distance	X	50~250mm
Auto Power Off	•	•
MAX/MIN	•	•
Data Hold	•	•
Backlight	•	•
Unit Selection	•	
Data Logging	100 Groups	100 Groups

GAS DETECTOR



Model	MS6310
Page	125
Alarm at level	10%~40%
Response Time	2 seconds
Warm up time	2 Minutes
Easy to Identify	•
Pinpoint Gas Leaks	•
Portable	•
High Sensitivity	•
Resume Original measurement	State after 7~10 min in clear air
Gas Detected	Natural gas, Methance, Ethane, Propane

PAT TESTER

CAT II
CAT III
CAT IV



Model	MS5911
Page	100
Safety Rating	CAT II 300V
Grounding	20Ω
Insulation Resistance	20MΩ
leakage Current	10.5mA
Cord Test	•
Polarity Test	•
Power Socket Test	•
Auto Power Off	•
Data HoldBacklight	•
Data logging	300 groups

ENVIRONMENT TESTER



Model	MS6300
Page	126
Auto Ranging	•
Auto Power Off	•
Temperature	-10~60°C/14~140°F
Humidity	20~80%RH
Sound level	30~130dB
luminance	2000Lux
Wind Speed	0.5~20m/s, 1.8~72km/h 100~4000FPM, 0.9~38.9Knots
AirFlow [CMM]	0~999900
AirFlow [CFM]	0~999900
A/C Weighting	•
MAX/MIN/AVG/DIF	•
Data Hold	•
Backlight	•

DISTANCE METERS



Model	MS6404/MS6406/MS6408
Page	127
Auto Power Off	•
Distance	40m/60m/80m
Accuracy	±2.0mm
Area & Volume	•
Pythagorean proposition measurement	•
Unit	mm/Inch/feet
Backlight	•
Auxiliary foot level	•
Laser target point	•
Data Logging	30 groups

STUD METAL DETECTOR



Model	MS6906
Page	128
Auto Power Off	7 Minute
Wooden Pillar	30mm
Metal Stud Detection Depth	30mm
Metal Pipe Detector Depth	50mm
AC Voltage Detection Depth	75mm (50~600VAC)
Data Hold	•
Backlight	•

PROCESS CALIBRATOR



Model	MS7221
Page	129
DC Voltage	10V
DC Current	10A
Loop Power Output	24V DC

DIGITAL MULTIMETERS

MANUAL RANGE | AUTO RANGE | POCKET & PEN TYPE
SPECIAL APPLICATION





MAIN APPLICATIONS



DOMESTIC

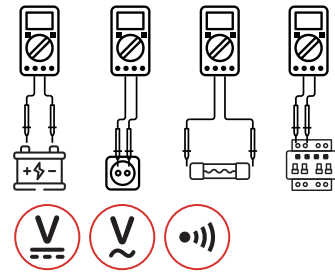

ELECTRONICS

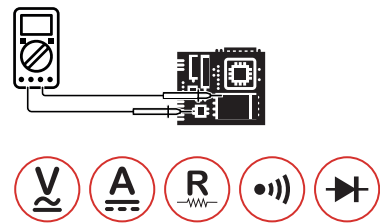

DIGITAL MULTIMETER

MS8233A

SKU NO.: MS8233ACBGLO
 UPC CODE: 810053673140
 EAN CODE: 8435394778877

FEATURE

- Diode Open Voltage 3.0V.
- Continuity Buzzer <60Ω.
- Data Hold.
- Low Battery Display.

SPECIFICATIONS

AC Voltage 600V	DC Voltage 600V	DC Current 10A
Resistance 2MΩ	Continuity <60Ω	Display Counts 2000

CONTENTS



140×67×30mm
 5.5"×2.6"×1.2"
 112g/0.25lb



1×9V 6F22
 Battery



ACCESSORIES

Test Leads
 Battery



Calibration
 Certificate



Quick Start
 Guide

PACKAGING INFORMATION



Color Box
 L145×W60×H188mm



Carton Box
 49×28×37cm



X 20PCS



MAIN APPLICATIONS



DOMESTIC

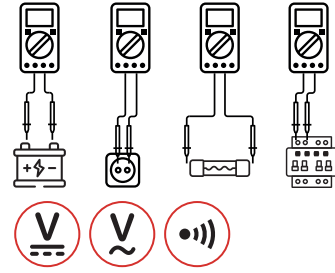

ELECTRONICS

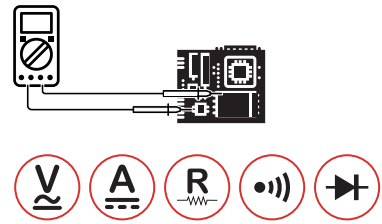

DIGITAL MULTIMETER

MS8233B

SKU NO.: MS8233BCBGLO
 UPC CODE: 810053674840
 EAN CODE: 8435394783369

FEATURE

- Diode Open Voltage 3.0V.
- Low Battery Display.
- Display Backlight.
- Non-contact Voltage Detection.

SPECIFICATIONS

AC Voltage 600V	DC Voltage 600V	DC Current 10A
Resistance 2MΩ	Continuity <60Ω	Display Counts 2000

CONTENTS



140×67×30mm
 5.5"×2.6"×1.2"
 112g/0.25lb



1×9V 6F22
 Battery



ACCESSORIES

Test Leads
 Battery



Calibration
 Certificate



Quick Start
 Guide

PACKAGING INFORMATION



Color Box
 L145×W60×H188mm



Carton Box
 40×32×31.5cm



X 20PCS



DIGITAL MULTIMETER

MS8233C

SKU NO.: MS8233CCBGLO
 UPC CODE: 810053672228
 EAN CODE: 8435394777948

FEATURE

- Diode Open Voltage 3.0V.
- Low Battery Display.
- Display Backlight.
- Non-contact Voltage Detection.

SPECIFICATIONS

AC Voltage 600V	DC Voltage 600V	DC Current 10A
Resistance 2MΩ	Continuity <60Ω	Display Counts 2000
Temperature -20°C~1000°C/-4°F~1832°F		

MAIN APPLICATIONS

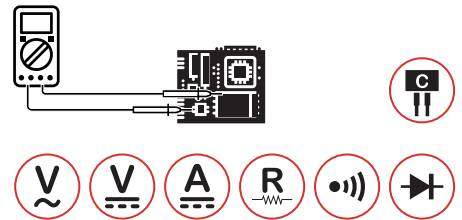
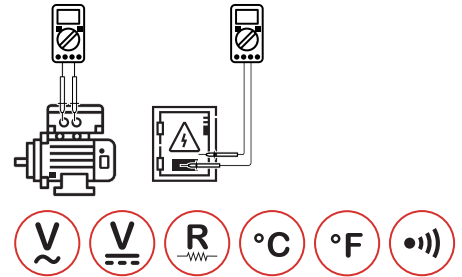
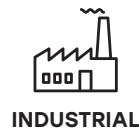
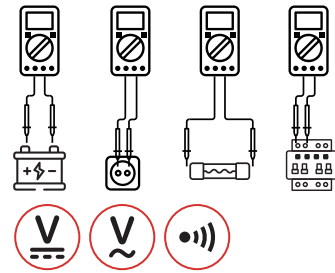

CONTENTS



140×67×30mm
 5.5"×2.6"×1.2"
 112g/0.25lb



1×9V 6F22
 Battery



ACCESSORIES

Test Leads
 K-type thermocouple
 Battery



Calibration
 Certificate



Quick Start
 Guide

PACKAGING INFORMATION



Color Box
 L145×W60×H188mm



Carton Box
 40×32×31.5cm



X 20PCS



MAIN APPLICATIONS



DOMESTIC

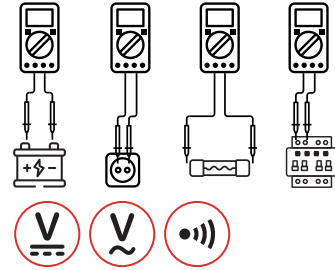

INDUSTRIAL

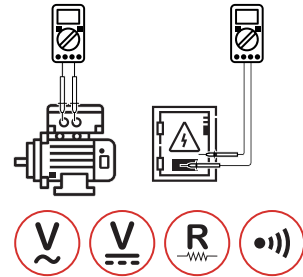

ELECTRONICS

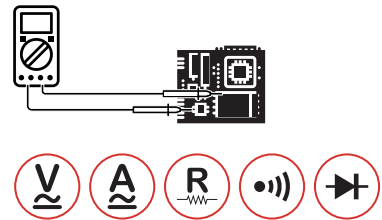

DIGITAL MULTIMETER
MS8360E

SKU NO.: MS8360ECBGLO
UPC CODE: 810053674499
EAN CODE: 8435394779560

FEATURE

- Auto Power Off.
- Non-Contact Voltage Detector.
- Transistor hFE 0~1000.
- Diode Open Voltage 3.0V.

SPECIFICATIONS

AC Voltage 600V	DC Voltage 600V	AC Current 10A
DC Current 10A	Resistance 200MΩ	Continuity test <50Ω
Capacitance 200μF	Frequency 20kHz	Display counts 2000

CONTENTS



188×92×50mm
7.4"×3.6"×2.0"
380g/0.83lb



1×9V 6F22
Battery



ACCESSORIES

Test leads
Multi-function socket
Battery



Calibration
Certificate



Quick Start
Guide

PACKAGING INFORMATION



Color Box
L165×W70×H225mm



Carton Box
47×37.5×35.5cm



X 20PCS



DIGITAL MULTIMETER MY70

SKU NO.: MY70CBGLO
UPC CODE: 810053672280
EAN CODE: 8435394778006

FEATURE

- Auto Power Off.
- Transistor hFE 0~1000.
- Diode Open Voltage 3.0V.
- Data Hold.

SPECIFICATIONS

AC Voltage 600V	DC Voltage 600V	AC Current 10A
DC Current 10A	Resistance 200MΩ	Continuity <50Ω
Display Counts 2000		

MAIN APPLICATIONS

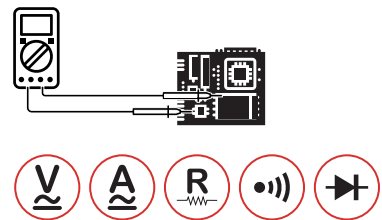
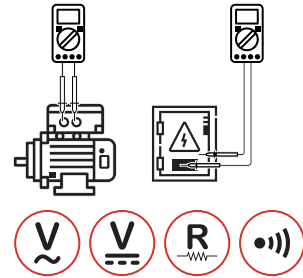
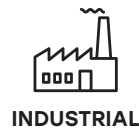
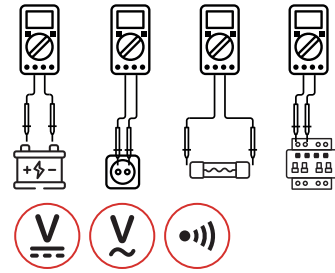

CONTENTS



188×93×50mm
7.4"×3.7"×1.96"
380g/0.84lb



1×9V 6F22
Battery



ACCESSORIES

Test leads
Multi-function socket
Battery



Calibration
Certificate



Quick Start
Guide

PACKAGING INFORMATION



Color Box
L165×W70×H225mm



Carton Box
47×37.5×35.5cm



X 20PCS



DIGITAL MULTIMETER
MY74

SKU NO.: MY74CBGLO
UPC CODE: 810053672297
EAN CODE: 8435394778013

FEATURE

- Auto Power Off.
- Transistor hFE 0~1000.
- Diode Open Voltage 3.0V.
- Data Hold.

SPECIFICATIONS

AC Voltage 600V	DC Voltage 600V	AC Current 10A
DC Current 10A	Resistance 200MΩ	Capacitance 100μF
Frequency 20kHz	Continuity <50Ω	Display Counts 2000
Temperature -20°C~1000°C		

MAIN APPLICATIONS

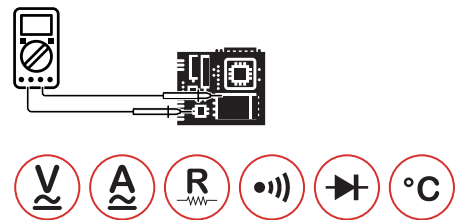
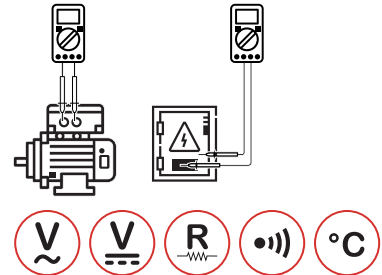
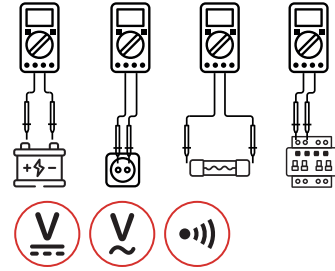

CONTENTS



188×93×50mm
7.4"×3.7"×1.96"
380g/0.84lb



1×9V 6F22
Battery



ACCESSORIES

Test leads
K type thermocouple
Multi-function socket
Battery



Calibration
Certificate



Quick Start
Guide

PACKAGING INFORMATION



Color Box
L165×W70×H225mm



Carton Box
47×37.5×35.5cm



X 20PCS



MAIN APPLICATIONS



DOMESTIC

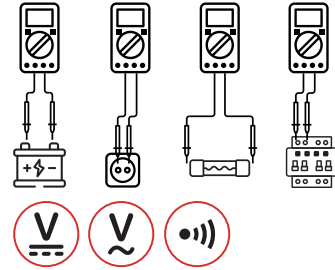

ELECTRONICS

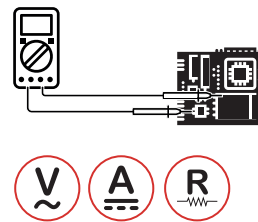

NEW

DIGITAL MULTIMETER

MS820L

SKU NO.: MS820LCBGLO
 UPC CODE: 810053678183
 EAN CODE: 8435394787787

FEATURE

- Display 2000 counts.
- Data Hold.
- Auto Power Off.

SPECIFICATIONS

AC Voltage 500V	DC Voltage 500V	DC Current 10A
Resistance 200MΩ	Continuity <50±20Ω	Display Counts 2000

CONTENTS



115x65x30mm
 4.5"x2.6"x1.2"
 170g/0.37lb



2x1.5V AAA
 Batteries



Test Leads
 Battery

ACCESSORIES



Calibration
 Certificate



Quick Start
 Guide

PACKAGING INFORMATION



Color Box
 L145xW50xH160mm



Carton Box
 53.8x30.8x17.8cm



X 20PCS



MAIN APPLICATIONS



DOMESTIC

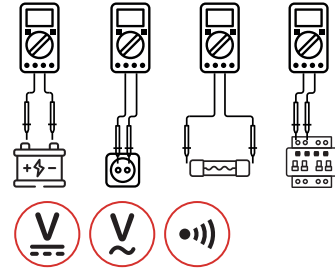

INDUSTRIAL

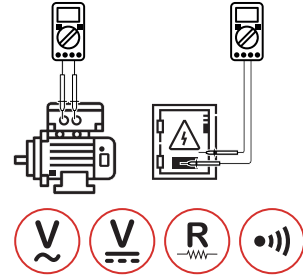

ELECTRONICS

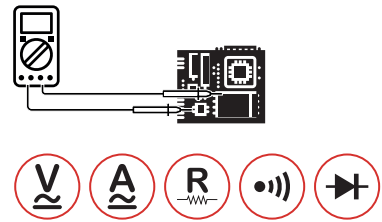

DIGITAL MULTIMETER
MS8233D

SKU NO.: MS8233DCBGLO
UPC CODE: 810053673201
EAN CODE: 8435394778938

FEATURE

- Non-contact Voltage Detection.
- Maximum Measurement.
- Display Backlight.
- Low Battery Display.

SPECIFICATIONS

AC Voltage 600V	DC Voltage 600V	AC Current 10A
DC Current 10A	Resistance 20MΩ	Continuity <60Ω
Display Counts 2000		

CONTENTS



140×67×30mm
5.5"×2.6"×1.2"
112g/0.25lb



1×9V 6F22
Battery



Test Leads
Battery

ACCESSORIES



Calibration
Certificate



Quick Start
Guide

PACKAGING INFORMATION



Color Box
L145×W60×H188mm



Carton Box
40×32×31.5cm



X 20PCS



MAIN APPLICATIONS



DOMESTIC

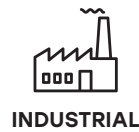
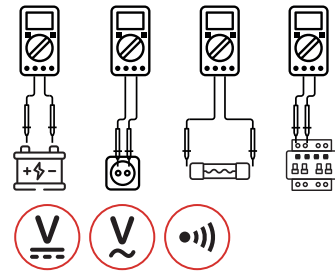

INDUSTRIAL

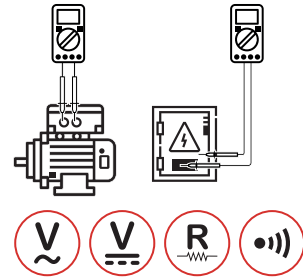

ELECTRONICS

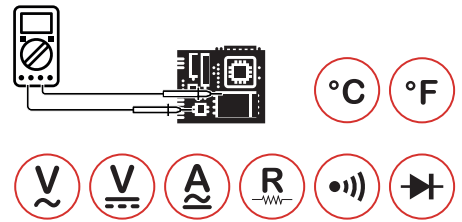

DIGITAL MULTIMETER
MS8233E

SKU NO.: MS8233ECBGLO
UPC CODE: 810053672259
EAN CODE: 8435394777979

FEATURE

- Non-contact Voltage Detection.
- Maximum Measurement.
- Display Backlight.
- Low Battery Display.

SPECIFICATIONS

AC Voltage 600V	DC Voltage 600V	AC Current 10A
DC Current 10A	Resistance 20MΩ	Continuity <60Ω
Display Counts 2000	Temperature -20°C~1000°C/-4°F~1832°F	

CONTENTS



140×67×30mm
5.5"×2.6"×1.2"
112g/0.25lb



1×9V 6F22
Battery



ACCESSORIES

Test leads
K type thermocouple
Battery



Calibration
Certificate



Quick Start
Guide

PACKAGING INFORMATION



Color Box
L145×W60×H188mm



Carton Box
40×32×31.5cm



X 20PCS



MAIN APPLICATIONS



DOMESTIC

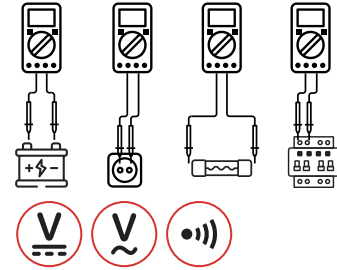

INDUSTRIAL

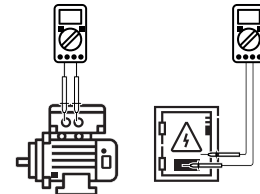

ELECTRONICS

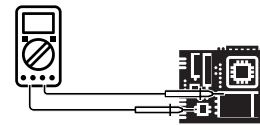

DIGITAL MULTIMETER WITH WIRELESS
MS8238H

SKU NO.: MS8238HCBGLO
UPC CODE: 810053675335
EAN CODE: 8435394783383

FEATURE

- Auto Power Off.
- True RMS For AC Voltage & AC Current.
- Wireless APP connection.
- Non-Contact Voltage Detector.

SPECIFICATIONS

AC Voltage 600V	DC Voltage 600V	AC Current 10A
DC Current 10A	Resistance 40MΩ	Continuity <50Ω
Display Counts 4000	Temperature -20°C~1000°C/-4°F~1832°F	

CONTENTS



148×73.5×50mm
5.8"×2.9"×1.96"
241g/0.53lb



1×9V 6F22
Battery



ACCESSORIES

Test leads
K type thermocouple
Battery



Calibration
Certificate



Quick Start
Guide

PACKAGING INFORMATION



Color Box
L145×W60×H188mm



Carton Box
40×32×31.5cm



X 20PCS



DIGITAL MULTIMETER

MS8239C

SKU NO.: MS8239CCBGLO
 UPC CODE: 810053672266
 EAN CODE: 8435394777986

FEATURE

- Auto & Manual Ranging.
- Auto Power Off.
- Diode Open Voltage 1.5V.
- Data Hold.

SPECIFICATIONS

AC Voltage 600V	DC Voltage 600V	AC Current 10A
DC Current 10A	Resistance 40MΩ	Continuity <50±20Ω
Frequency 10kHz	Temperature -20°C~1000°C/-4°F~1832°F	
Display Counts 4000		

MAIN APPLICATIONS

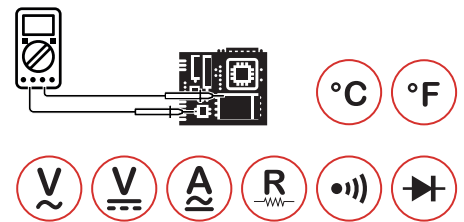
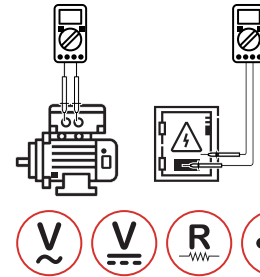
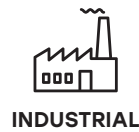
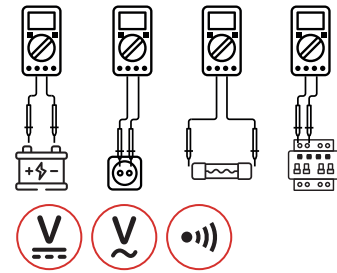

CONTENTS



150×74×41mm
 5.9"×2.9"×1.6"
 202g/0.44lb



2×1.5V AAA
 Batteries



ACCESSORIES

Test leads
 K type thermocouple
 Battery



Calibration
 Certificate



Quick Start
 Guide

PACKAGING INFORMATION



Color Box
 L145×W60×H188mm



Carton Box
 40×32×31.5cm



X 20PCS



MAIN APPLICATIONS



DOMESTIC

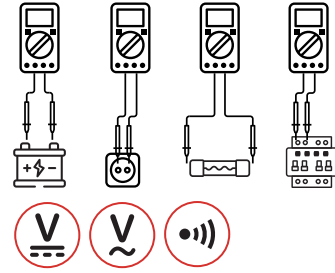

INDUSTRIAL

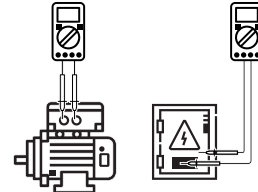

ELECTRONICS

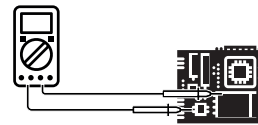

DIGITAL MULTIMETER
MS8250A

SKU NO.: MS8250ACBGLO
UPC CODE: 810053672679
EAN CODE: 8435394778310

FEATURE

- Auto & Manual Ranging.
- Auto Power Off.
- Relative Measurement.
- Non-Contact Voltage Detector.

SPECIFICATIONS

AC Voltage 600V	DC Voltage 600V	AC Current 10A
DC Current 10A	Resistance 40MΩ	Continuity <50±20Ω
Capacitance 100μF	Frequency 5MHz	Display Counts 4000

CONTENTS



175x86x52mm
6.89"x3.38"x2.04"
372g/0.82lb



1x9V 6F22
Battery



Test Leads
Battery

ACCESSORIES



Calibration
Certificate



Quick Start
Guide

PACKAGING INFORMATION



Color Box
L165xW70xH225mm



Carton Box
47x37.5x35.5cm



X 20PCS



DIGITAL MULTIMETER WITH USB **MS8250D**

SKU NO.: MS8250DCBGLO
UPC CODE: 810053674413
EAN CODE: 8435394779485

FEATURE

- Auto & Manual Ranging.
- Auto Power Off.
- True RMS.
- Non-Contact Voltage Detector.

SPECIFICATIONS

AC Voltage 1000V	DC Voltage 1000V	AC Current 10A
DC Current 10A	Resistance 66MΩ	Continuity test <50Ω
Capacitance 66mF	Frequency 66MHz	Display counts 6600

MAIN APPLICATIONS



DOMESTIC

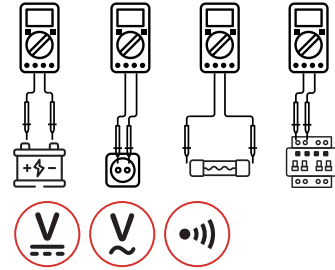

INDUSTRIAL

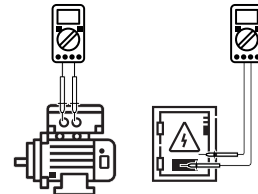

ELECTRONICS



CONTENTS



175×86×52mm
6.89"×3.38"×2.04"
372g/0.82lb



1×9V 6F22
Battery



ACCESSORIES

Test Leads
USB interface cable
Software CD
Battery



Calibration
Certificate



Quick Start
Guide

PACKAGING INFORMATION



Color Box
L165×W70×H225mm



Carton Box
47×37.5×35.5cm



X 20PCS



DIGITAL MULTIMETER
MS8251A

SKU NO.: MS8251ACBGLO
UPC CODE: 810053673157
EAN CODE: 8435394778884

FEATURE

- Auto & Manual Ranging.
- Auto Power Off.
- True RMS.
- Non-Contact Voltage Detector.

SPECIFICATIONS

AC Voltage 1000V	DC Voltage 1000V	AC Current 10A
DC Current 10A	Resistance 66MΩ	Continuity <50±20Ω
Capacitance 66mF	Frequency 66MHz	Display Counts 6600

MAIN APPLICATIONS

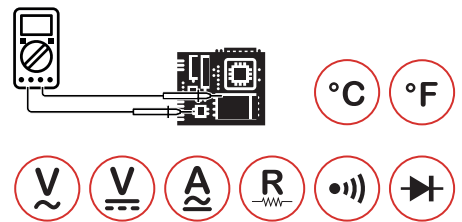
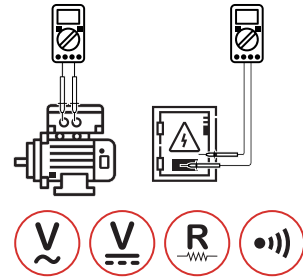
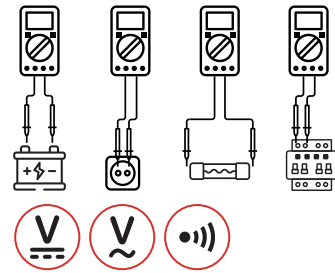

CONTENTS



175×85×52mm
6.89"×3.3"×2.1"
420g/0.92lb



1×9V 6F22
Battery



ACCESSORIES

Test leads
K type thermocouple
Multi-function socket
Carrying strap
Battery



Calibration
Certificate



Quick Start
Guide

PACKAGING INFORMATION



Color Box
L165×W70×H225mm



Carton Box
47×37.5×35.5cm



X 20PCS



DIGITAL MULTIMETER

MS8251B

SKU NO.: MS8251BCBGLO
 UPC CODE: 810053672686
 EAN CODE: 8435394778327

FEATURE

- Auto & Manual Ranging.
- Auto Power Off.
- Relative Measurement.
- Non-Contact Voltage Detector.

SPECIFICATIONS

AC Voltage 1000V	DC Voltage 1000V	AC Current 10A
DC Current 10A	Resistance 66MΩ	Continuity <50±20Ω
Capacitance 66mF	Frequency 10kHz	Display Counts 6600
Temperature 0°C~1000°C/32°F~1832°F		

MAIN APPLICATIONS



DOMESTIC

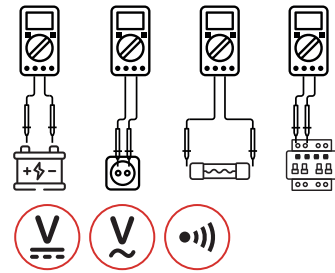

INDUSTRIAL

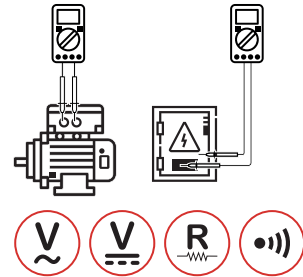

ELECTRONICS

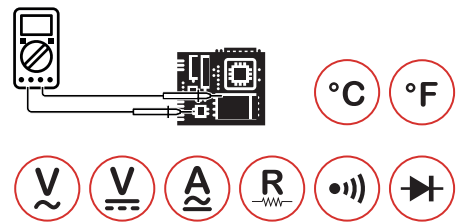

CONTENTS



175×85×52mm
 6.9"×3.3"×2.1"
 420g/0.92lb



1×9V 6F22
 Battery



ACCESSORIES

Test leads
 K type thermocouple
 Multi-function socket
 Carrying strap
 Battery



Calibration
 Certificate



Quick Start
 Guide

PACKAGING INFORMATION



Color Box
 L165×W70×H225mm



Carton Box
 47×37.5×35.5cm



X 20PCS



MAIN APPLICATIONS

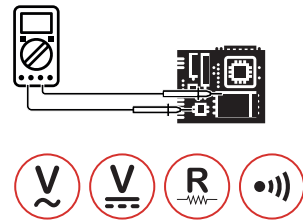
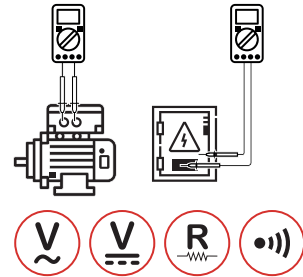
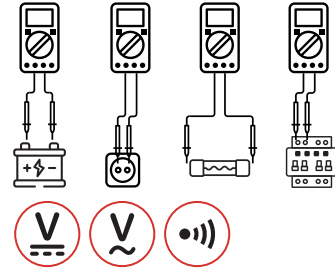

**DIGSMART DIGITAL MULTIMETER
MS8301D**

SKU NO.: MS8301DCBGLO
UPC CODE: 810053672273
EAN CODE: 8435394777993

FEATURE

- Auto Ranging.
- Auto Power Off.
- Dual Display.
- Continuity Buzzer.

SPECIFICATIONS

AC Voltage 600V	DC Voltage 600V	Resistance 10MΩ
Frequency 3kHz	Continuity <40Ω	Display Counts 6000

CONTENTS



150×74×48mm
5.9"×2.9"×1.7"
220g/0.48lb



2×1.5V AAA
Batteries



ACCESSORIES

Test Leads
Battery



Calibration
Certificate



Quick Start
Guide

PACKAGING INFORMATION



Color Box
L145×W60×H188mm



Carton Box
40×32×31.5cm



X 20PCS



DIGITAL MULTIMETER

MS8340A

SKU NO.: MS8340ACBGLO
 UPC CODE: 810053675359
 EAN CODE: 8435394783000

FEATURE

- Auto & Manual Ranging.
- Auto Power Off.
- Relative Measurement.
- Low Pass Filter 1kHz.

SPECIFICATIONS

AC Voltage 750V	DC Voltage 1000V	AC Current 10A
DC Current 10A	Resistance 60MΩ	Continuity <50±20Ω
Capacitance 400μF	Frequency 10MHz	Display Counts 6000
Temperature -10°C~700°C/-14°F~1292°F		

MAIN APPLICATIONS

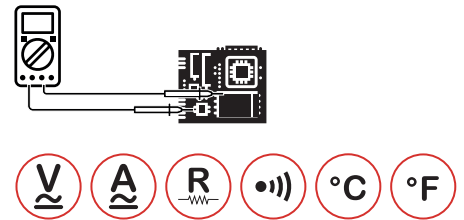
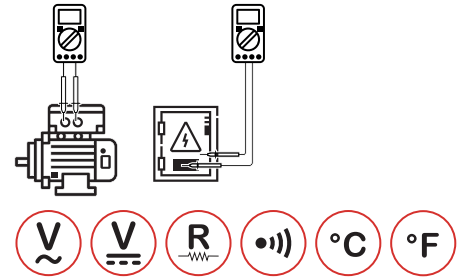
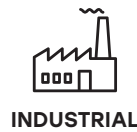
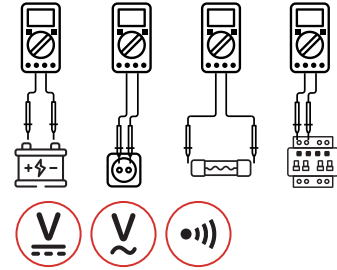

CONTENTS



205x102x58mm
 8.1"x4.0"x2.2"
 390g/0.86lb



4x1.5V AA Batteries



ACCESSORIES

Test leads
 K type thermocouple
 Multi-function socket
 Battery



Calibration Certificate



Quick Start Guide

PACKAGING INFORMATION



Color Box
 L173xW85xH235mm



Carton Box
 49x45x37.2cm



X 20PCS



MAIN APPLICATIONS



DOMESTIC

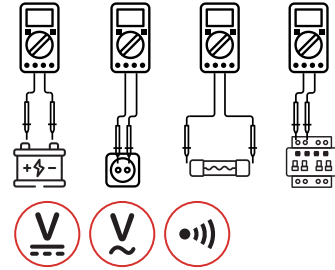

INDUSTRIAL

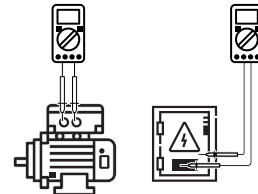

ELECTRONICS

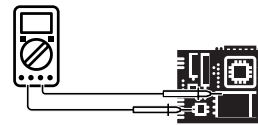

DIGITAL MULTIMETER
MS8360F

SKU NO.: MS8360FCBGLO
UPC CODE: 810053676783
EAN CODE: 8435394785325

FEATURE

- Auto & Manual Ranging.
- Auto Power Off.
- Relative Measurement.
- Non-Contact Voltage Detector.

SPECIFICATIONS

AC Voltage 600V	DC Voltage 600V	AC Current 10A
DC Current 10A	Resistance 40MΩ	Continuity <50±20Ω
Capacitance 200µF	Frequency 10MHz	Display Counts 4000

CONTENTS



188×92×50mm
7.4"×3.6"×2.0"
380g/0.83lb



1×9V 6F22
Battery



ACCESSORIES

Test leads
Multi-function socket
Battery



Calibration
Certificate



Quick Start
Guide

PACKAGING INFORMATION



Color Box
L165×W70×H225mm



Carton Box
47×37.5×35.5cm



X 20PCS



DIGITAL MULTIMETER

MS8360G

SKU NO.: MS8360GCBGLO
 UPC CODE: 810053672075
 EAN CODE: 8435394777801

FEATURE

- Auto & Manual Ranging.
- Auto Power Off.
- Relative Measurement.
- Non-Contact Voltage Detector.

SPECIFICATIONS

AC Voltage 600V	DC Voltage 600V	AC Current 10A
DC Current 10A	Resistance 40MΩ	Continuity <50±20Ω
Capacitance 4000μF	Frequency 10MHz	Display Counts 4000
Temperature -20°C~1000°C/-4°F~1832°F		

MAIN APPLICATIONS

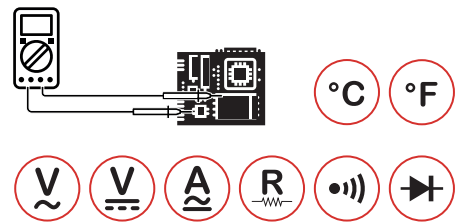
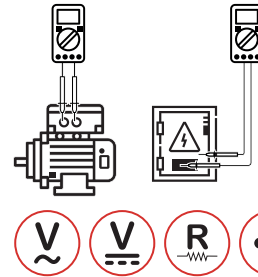
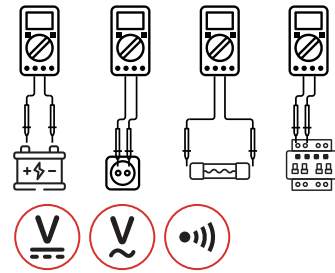

CONTENTS



188×92×50mm
 7.4"×3.6"×2.0"
 380g/0.83lb



1×9V 6F22
 Battery



ACCESSORIES

Test leads
 K type thermocouple
 Multi-function socket
 Battery



Calibration
 Certificate



Quick Start
 Guide

PACKAGING INFORMATION



Color Box
 L165×W70×H225mm



Carton Box
 47×37.5×35.5cm



X 20PCS



MAIN APPLICATIONS



DOMESTIC

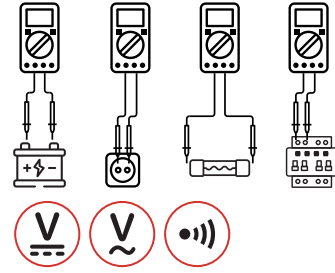

INDUSTRIAL

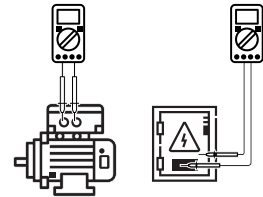

ELECTRONICS

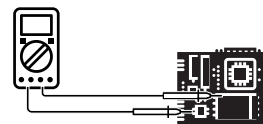

DIGITAL MULTIMETER WITH WIRELESS
MS8361D

SKU NO.: MS8361DCBGLO
UPC CODE: 810053675366
EAN CODE: 8435394783406

FEATURE

- Auto & Manual Ranging.
- Auto Power Off.
- True RMS For AC Voltage & AC Current.
- Wireless APP connection.

SPECIFICATIONS

AC Voltage 600V	DC Voltage 600V	AC Current 10A
DC Current 10A	Resistance 40MΩ	Continuity <50Ω
Capacitance 99.99mF	Frequency 10kHz	Display Counts 4000

CONTENTS



188×92×50mm
7.4"×3.6"×2.0"
380g/0.83lb



1×9V 6F22
Battery



ACCESSORIES

Test leads
Multi-function socket
Battery



Calibration
Certificate



Quick Start
Guide

PACKAGING INFORMATION



Color Box
L165×W70×H225mm



Carton Box
47×37.5×35.5cm



X 20PCS



MAIN APPLICATIONS



DOMESTIC

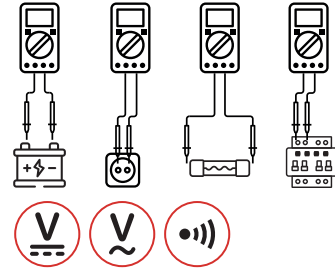

ELECTRONICS

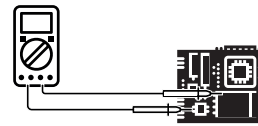

POCKET DIGITAL MULTIMETER
M300

SKU NO.: M300CBGLO
UPC CODE: 810053672082
EAN CODE: 8435394777818

FEATURE

- Pocket format that facilitates product portability.
- Test leads integrated which facilitates its use and storage.

SPECIFICATIONS

AC Voltage 600V	DC Voltage 600V	DC Current 200mA
Resistance 2MΩ	Display Counts 2000	Continuity <50±20Ω

CONTENTS



120×70×18mm
4.7"×2.75"×0.7"
110g/0.23lb



1x12V A23S
Battery



ACCESSORIES

Test leads
Carry bag



Calibration
Certificate



Quick Start
Guide

PACKAGING INFORMATION



Color Box
L95xW35xH154mm



Carton Box
37x32.8x21.5cm



X 40PCS



MAIN APPLICATIONS

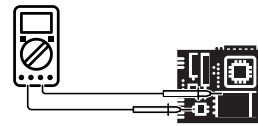
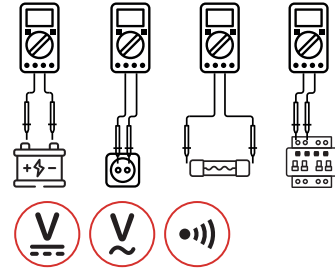

ELECTRONICS



POCKET DIGITAL MULTIMETER
M320

SKU NO.: M320CBGLO
UPC CODE: 810053674048
EAN CODE: 8435394779119

FEATURE

- Auto Ranging.
- Auto Power Off.
- Diode Open Voltage 1.5V.
- Data Hold.

SPECIFICATIONS

AC Voltage 600V	DC Voltage 600V	AC Current 400mA
DC Current 400mA	Resistance 40MΩ	Frequency 100kHz
Display Counts 4000	Continuity <50±20Ω	

CONTENTS



120×70×18mm
4.7"×2.75"×0.7"
110g/0.23lb



2×1.5V 357A(LR44)
Batteries



Test leads
Carry bag

ACCESSORIES



Calibration
Certificate



Quick Start
Guide

PACKAGING INFORMATION



Color Box
L95xW35xH154mm



Carton Box
37x32.8x21.5cm



X 40PCS



MAIN APPLICATIONS

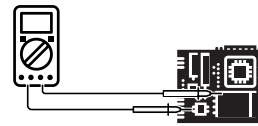
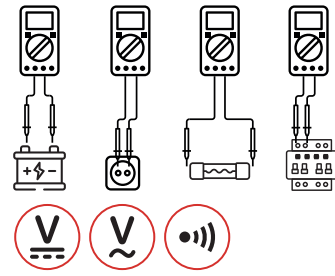

POCKET DIGITAL MULTIMETER
MS8333A

SKU NO.: MS8333ACBGLO
UPC CODE: 810053674482
EAN CODE: 8435394779553

FEATURE

- Auto Ranging.
- Auto Power Off.
- True RMS For AC Voltage & AC Current.
- Non-Contact Voltage Detector.

SPECIFICATIONS

AC Voltage 600V	DC Voltage 600V	AC Current 600mA
DC Current 600mA	Resistance 60MΩ	Continuity <50±20Ω
Capacitance 600μF	Frequency 10kHz	Display Counts 6000

CONTENTS



122×62×44mm
4.8"×2.44"×1.73"
186g/0.4lb



2×1.5V AAA
Batteries



Test leads
Battery

ACCESSORIES



Calibration
Certificate



Quick Start
Guide

PACKAGING INFORMATION



Color Box
L145×W60×H188mm



Carton Box
40×32×31.5cm



X 20PCS



MAIN APPLICATIONS



DOMESTIC

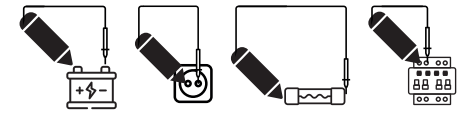

ELECTRONICS

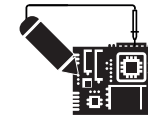

PEN-TYPE DIGITAL MULTIMETER
MS8211

SKU NO.: MS8211CBGLO
UPC CODE: 810053673010
EAN CODE: 8435394778976

FEATURE

- Auto & Manual Ranging.
- Auto Power Off.
- Diode Open Voltage 1.5V.
- Maximum Value Hold.

SPECIFICATIONS

AC Voltage 600V	DC Voltage 600V	Resistance 20MΩ
Continuity <50±20Ω	Display Counts 2000	

CONTENTS



208×38×29mm
8.26"×1.5"×1.1"
110g/0.24lb



2×1.5V AAA
Batteries



ACCESSORIES

Test leads
Alligator Clips
Carry bag
Battery



Calibration
Certificate



Quick Start
Guide

PACKAGING INFORMATION



Color Box
L85×W45×H220mm



Carton Box
46×26×36cm



X 40PCS



MAIN APPLICATIONS



DOMESTIC

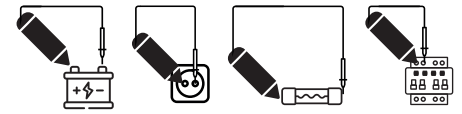

ELECTRONICS

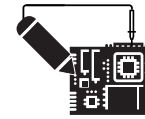

PEN-TYPE DIGITAL MULTIMETER
MS8212A

SKU NO.: MS8212ACBGLO
UPC CODE: 810053673034
EAN CODE: 8435394778761

FEATURE

- Auto & Manual Ranging.
- Auto Power Off.
- Diode Open Voltage 1.5V.
- Maximum Value Hold.

SPECIFICATIONS

AC Voltage 600V	DC Voltage 600V	AC Current 200mA
DC Current 200mA	Resistance 20MΩ	Continuity <50±20Ω
Display Counts 2000		

CONTENTS



238×43×29mm
9.37"×1.7"×1.1"
112g/0.28lb



2×1.5V AAA
Batteries



ACCESSORIES

Test leads
Alligator Clips
Carry bag
Battery



Calibration
Certificate



Quick Start
Guide

PACKAGING INFORMATION



Color Box
L85×W45×H236mm



Carton Box
49×28×37cm



X 40PCS



MAIN APPLICATIONS

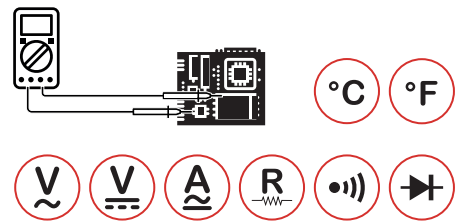
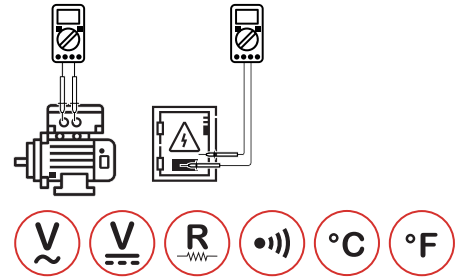
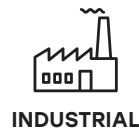
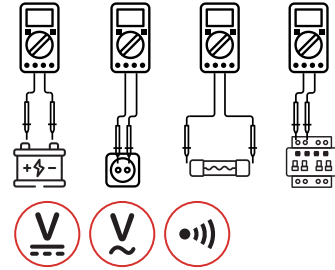

DIGITAL INSULATION MULTIMETER
MS5208

SKU NO.: MS5208CBGLO
UPC CODE: 810053673065
EAN CODE: 8435394778792

FEATURE

- Auto & Manual Ranging.
- Auto Power Off.
- True RMS For AC Voltage & AC Current.
- DAR/PI Mod.

SPECIFICATIONS

AC Voltage 750V	DC Voltage 1000V	AC Current 400mA
DC Current 400mA	DC Output 1000V	Resistance 66MΩ
Capacitance 66mF	Frequency 10kHz	Continuity <30Ω
Display Counts 6600	Temperature -30°C~1300°C / -22°F~2372°F	

CONTENTS



205x102x58mm
8.1"x4.0"x2.3"
390g/0.86lb



4x1.5V AA Batteries



ACCESSORIES

Test Leads
Test Clips
K Type Thermocouple
Multi-function socket
Carry Bag
Battery



Calibration Certificate



Quick Start Guide

PACKAGING INFORMATION



Color Box
L172xW80xH255mm



Carton Box
53x44.5x37cm



X 20PCS



DIGITAL MULTIMETER WITH ENVIRONMENT 5 IN 1

MS8229

SKU NO.: MS8229CBAGLO
 UPC CODE: 810053672327
 EAN CODE: 8435394778433

FEATURE

- Hinged Bracket Facilitate Table Work.
- Auto-Ranging, Relative, Humidity, Luminosity & Sound level.
- For Professional Use.

SPECIFICATIONS

AC Voltage 750V	DC Voltage 1000V	AC Current 10A
DC Current 10A	Resistance 40MΩ	Capacitance 100uF
Frequency >200kHz	Continuity <50±20Ω	Display Counts 4000
Temperature -20°C~1000°C/-4°F~1832°F		

MAIN APPLICATIONS



DOMESTIC

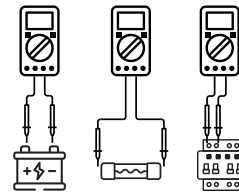

INDUSTRIAL

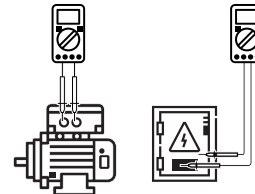

ELECTRONICS

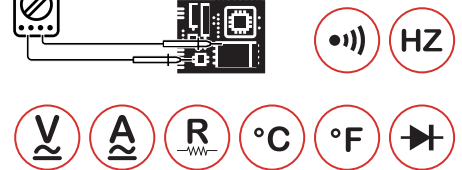
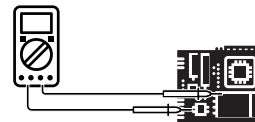

CONTENTS



195×92×55mm
 7.7"×3.6"×2.2"
 390g/0.86lb



3×1.5V AAA Batteries



ACCESSORIES

Test leads
 K type thermocouple
 Battery



Calibration Certificate



Quick Start Guide

PACKAGING INFORMATION



Color Box
 L165×W70×H225mm



Carton Box
 47×37.5×35.5cm



X 20PCS

DIGITAL CLAMP METERS

AC CURRENT | AC/DC CURRENT | LEAKAGE | POWER
SPECIAL APPLICATION





MAIN APPLICATIONS

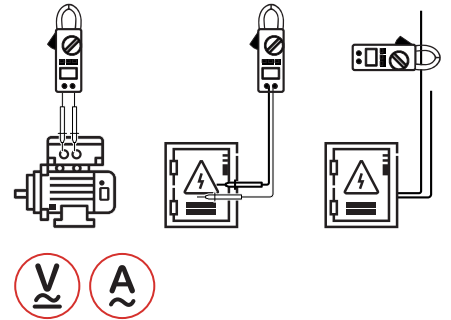
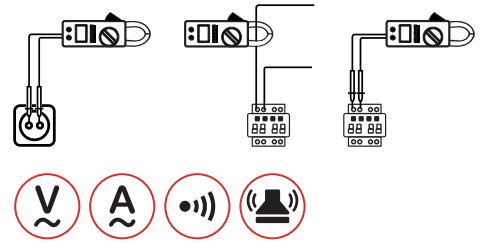

DIGITAL AC ELECTRICAL TESTER
M266

SKU NO.: M266CBGLO
UPC CODE: 810053673287
EAN CODE: 8435394779010

FEATURE

- Data Hold.
- Low Battery Display.

SPECIFICATIONS

AC Voltage 750V	DC Voltage 1000V	AC Current 1000A
Resistance 20kΩ	Display Counts 2000	Continuity <100Ω
Jaw Opening 50mm/2.0"		

CONTENTS



235×96×46mm
9.25"×3.8"×1.8"
268g/0.59lb



1×9V 6F22
Battery



ACCESSORIES

Test Leads
Carry bag
Battery



Calibration
Certificate



Quick Start
Guide

PACKAGING INFORMATION



Color Box
L130×W63×H255mm



Carton Box
53×34×28.5cm



X20PCS



MAIN APPLICATIONS

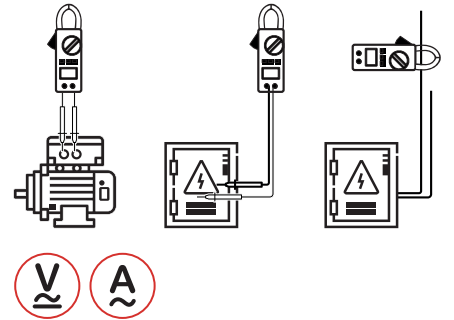
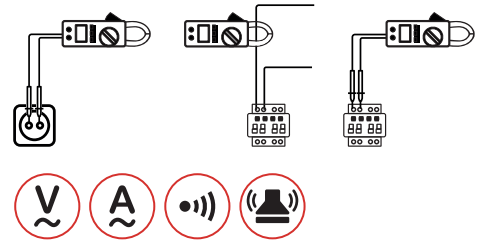

DIGITAL AC CLAMP METER
MS2001

SKU NO.: MS2001CBGLO
UPC CODE: 810053672341
EAN CODE: 8435394778044

FEATURE

- Diode Open Voltage 3.0V.
- Data Hold.
- Display Backlight.
- Low Battery Display.

SPECIFICATIONS

AC Voltage 750V	DC Voltage 1000V	AC Current 1000A
Resistance 2000Ω	Display Counts 2000	Jaw Opening 42mm/1.7"
Continuity <60Ω		

CONTENTS



250×99×43mm
9.8"×3.9"×1.7"
416g/0.92lb



1×9V 6F22
Battery



ACCESSORIES

Test Leads
Wrapping Case
Battery



Calibration
Certificate



Quick Start
Guide

PACKAGING INFORMATION



Color Box
L130×W60×H300mm



Carton Box
35.5×33×29cm



X 10PCS



MAIN APPLICATIONS



DOMESTIC

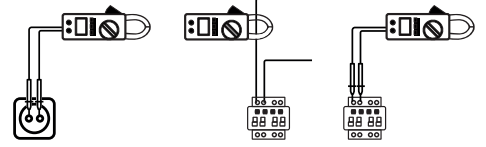

INDUSTRIAL

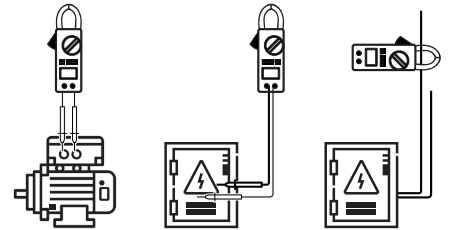

DIGITAL AC CLAMP METER
MS2001C

SKU NO.: MS2001CCBGLO
UPC CODE: 810053674109
EAN CODE: 8435394783055

FEATURE

- Data Hold.
- Display Backlight.
- Low Battery Display.

SPECIFICATIONS

AC Voltage 750V	DC Voltage 1000V	AC Current 1000A
Resistance 2000Ω	Display Counts 2000	Jaw Opening 42mm/1.7"
Continuity <60Ω	Temperature -40°C~750°C	

CONTENTS



250×99×43mm
9.8"×3.9"×1.7"
416g/0.92lb



1×9V 6F22
Battery



ACCESSORIES

Test Leads
K-type thermocouple
Carry bag
Battery



Calibration
Certificate



Quick Start
Guide

PACKAGING INFORMATION



Color Box
L130×W60×H300mm



Carton Box
35.5×33×29cm



X 10PCS



MAIN APPLICATIONS



DOMESTIC

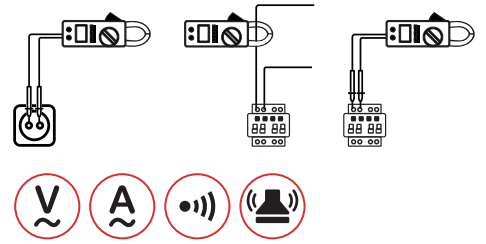

INDUSTRIAL

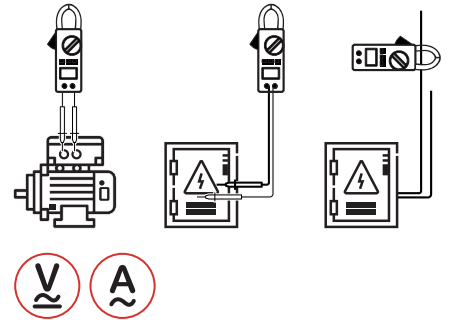

DIGITAL AC CLAMP METER
MS2009A

SKU NO.: MS2009ACBGLO
UPC CODE: 810053672549
EAN CODE: 8435394778181

FEATURE

- Auto & Manual Ranging.
- Auto Power Off.
- Non-Contact Voltage Detector.
- Diode Open Volatge 1.5V.

SPECIFICATIONS

AC Voltage 600V	DC Voltage 600V	AC Current 600A
Resistance 20MΩ	Display Counts 2000	Jaw Opening 26mm/1.0"
Continuity <60Ω		

CONTENTS



218×78×35mm
8.9"×3.1"×1.4"
239g/0.53lb



3×1.5V AAA
Batteries



ACCESSORIES

Test Leads
Carry bag
Battery



Calibration
Certificate



Quick Start
Guide

PACKAGING INFORMATION



Color Box
L105×W55×H235mm



Carton Box
50×30.5×23cm



X 20PCS



MAIN APPLICATIONS

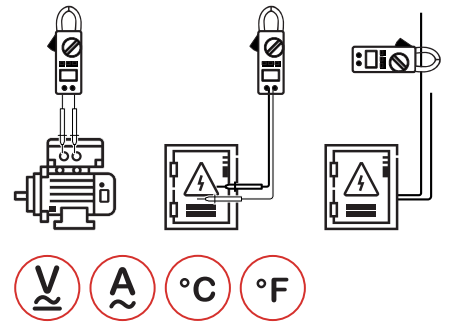
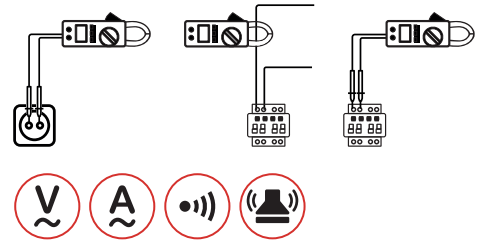

DIGITAL AC CLAMP METER
MS2009C

SKU NO.: MS2009CCBGLO
UPC CODE: 810053674130
EAN CODE: 8435394779201

FEATURE

- Auto & Manual Ranging.
- Auto Power Off.
- Non-Contact Voltage Detector.
- Diode Open Voltage 3.2V.

SPECIFICATIONS

AC Voltage 600V	DC Voltage 600V	AC Current 600A
Resistance 60MΩ	Capacitance 60mF	Frequency 1kHz
Display Counts 6000	Jaw Opening 26mm/1.0"	Continuity <50Ω
Temperature -20°C~1000°C/-4°F~1832°F		

CONTENTS



218×78×35mm
8.9"×3.1"×1.4"
239g/0.53lb



3×1.5V AAA
Batteries



ACCESSORIES

Test Leads
K-type thermocouple
Carry bag
Battery



Calibration
Certificate



Quick Start
Guide

PACKAGING INFORMATION



Color Box
L105×W55×H235mm



Carton Box
50×30.5×23cm



X 20PCS



MAIN APPLICATIONS

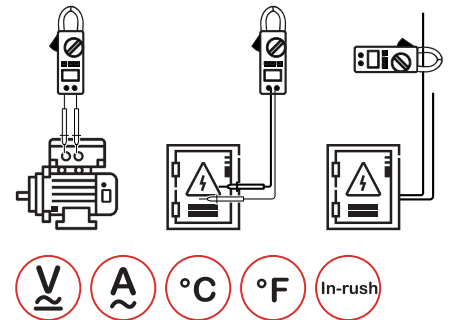
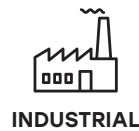
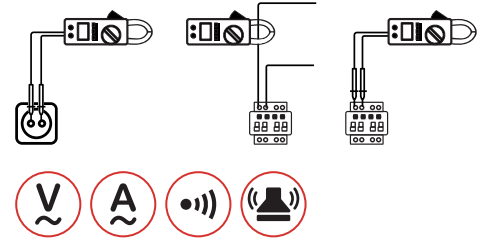

DIGITAL AC CLAMP METER MS2025C

SKU NO.: MS2025CCBGLO
UPC CODE: 810053674635
EAN CODE: 8435394779690

FEATURE

- Auto & Manual Ranging.
- Auto Power Off.
- Non-Contact Voltage Detector.
- Relative Measurement.

SPECIFICATIONS

AC Voltage 750V	DC Voltage 1000V	AC Current 1000A
Resistance 66MΩ	Capacitance 66mF	Continuity <50Ω
Frequency(A) 660Hz	Frequency(V) 6.6kHz	Display Counts 6600
Jaw Opening 40mm/1.6"	Temperature -20°C~1000°C/-4°F~1832°F	

CONTENTS



238×92×50mm
9.37"×3.6"×1.9"
390g/0.86lb



1×9V 6F22
Battery



ACCESSORIES

Test Leads
K-type thermocouple
Carry bag
Battery



Calibration
Certificate



Quick Start
Guide

PACKAGING INFORMATION



Color Box
L130×W63×H255mm



Carton Box
53×34×28.5cm



X 20CS



MAIN APPLICATIONS

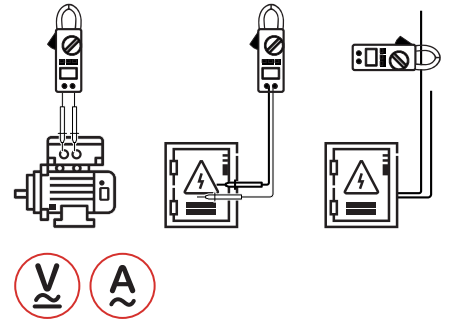
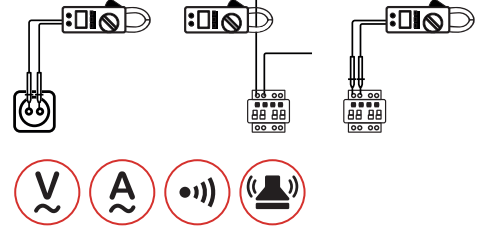

DIGITAL AC CLAMP METER
MS2028A

SKU NO.: MS2028ACBGLO
UPC CODE: 810053674642
EAN CODE: 8435394779706

FEATURE

- Auto & Manual Ranging.
- Auto Power Off.
- Diode Open Voltage 1.5V.
- True Root Mean Square.

SPECIFICATIONS

AC Voltage 600V	DC Voltage 600V	DC Current 600A
Resistance 20MΩ	Display Counts 2000	Jaw Opening 26mm/1.0"
Continuity <50Ω		

CONTENTS



208×78×35mm
8.2"×3.1"×1.4"
245g/0.54lb



3×1.5V AAA
Batteries



ACCESSORIES

Test Leads
Carry bag
Battery



Calibration
Certificate



Quick Start
Guide

PACKAGING INFORMATION



Color Box
L105×W55×H235mm



Carton Box
50×30.5×23cm



X 20PCS



MAIN APPLICATIONS

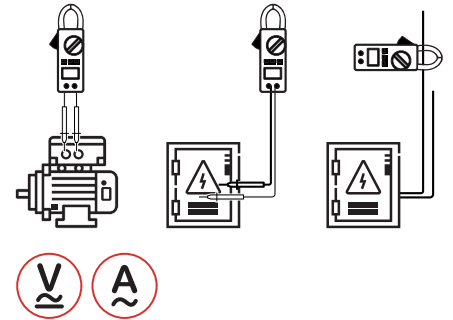
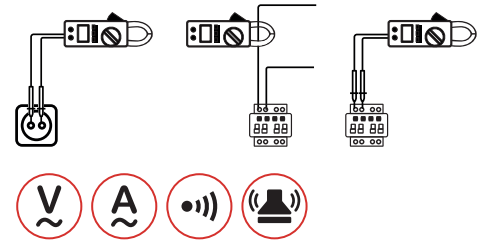

DIGITAL AC CLAMP METER
MS2030

SKU NO.: MS2030CBGLO
UPC CODE: 810053672556
EAN CODE: 8435394778198

FEATURE

- Diode Open Voltage 4.5V.
- Data Hold.
- Low Battery Display.

SPECIFICATIONS

AC Voltage 600V	DC Voltage 600V	AC Current 400A
Resistance 2kΩ	Display Counts 2000	Jaw Opening 28mm/1.1"
Continuity <50±20Ω		

CONTENTS



198×79×38mm
7.8"×3.1"×1.5"
195g/0.43lb



3×1.5V AAA
Batteries



ACCESSORIES

Test Leads
Carry bag
Battery



Calibration
Certificate



Quick Start
Guide

PACKAGING INFORMATION



Color Box
L105×W55×H235mm



Carton Box
50×30.5×23cm



X 20PCS



MAIN APPLICATIONS

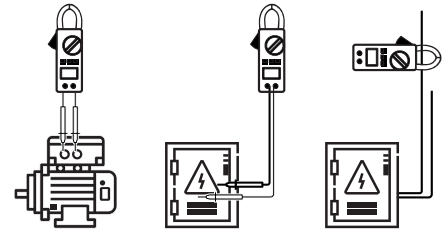
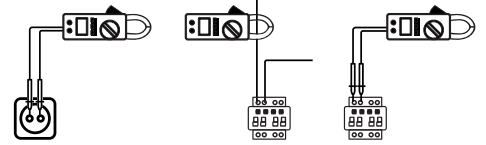

SMART DIGITAL CLAMP METER
MS2033A

SKU NO.: MS2033ACBGLO
UPC CODE: 810053674932
EAN CODE: 8435394782676

FEATURE

- Auto Ranging.
- Auto Power Off.
- Dual Display.
- MAX/MIN.

SPECIFICATIONS

AC Voltage 600V	DC Voltage 600V	AC Current 600A
Resistance 10MΩ	Frequency 3kHz	Display Counts 6000
Jaw Opening 26mm/1.0"	Continuity <40Ω	

CONTENTS



204x78x43mm
8"x3.07"x1.77"
195g/0.43lb



3x1.5V AAA
Batteries



ACCESSORIES

Test Leads
Carry bag
Battery



Calibration
Certificate



Quick Start
Guide

PACKAGING INFORMATION



Color Box
L105xW55xH235mm



Carton Box
50x30.5x23cm



X 20PCS



MAIN APPLICATIONS

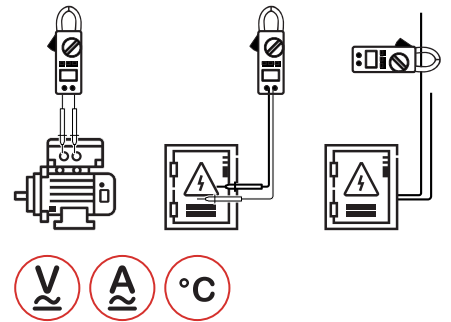
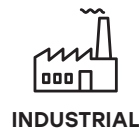
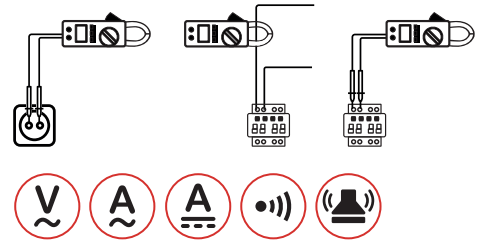

DIGITAL AC/DC CLAMP METER
MS2109A

SKU NO.: MS2109ACBGLO
UPC CODE: 810053672112
EAN CODE: 8435394777849

FEATURE

- Auto Ranging.
- Auto Power Off.
- Non-Contact Voltage Detector.
- Relative Measurement.

SPECIFICATIONS

AC Voltage 600V	DC Voltage 600V	AC Current 600A
DC Current 600A	Resistance 60MΩ	Capacitance 4000μF
Frequency 10kHz	Display Counts 6000	Jaw Opening 26mm/1.0"
Temperature -20°C~1000°C/-4°F~1832°F		Continuity <50±20Ω

CONTENTS



218×78×35mm
8.9"×3.1"×1.4"
239g/0.53lb



3×1.5V AAA
Batteries



ACCESSORIES

Test Leads
K-type thermocouple
Carry bag
Battery



Calibration
Certificate



Quick Start
Guide

PACKAGING INFORMATION



Color Box
L105xW55xH235mm



Carton Box
50×30.5×23cm



X 20PCS



MAIN APPLICATIONS

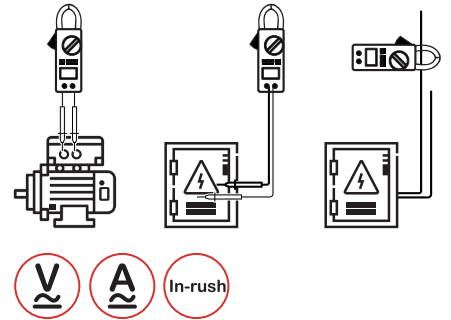
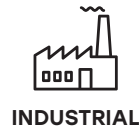
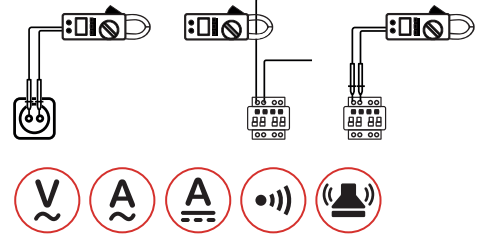

DIGITAL AC/DC CLAMP METER
MS2125A

SKU NO.: MS2125ACBGLO
UPC CODE: 810053672129
EAN CODE: 8435394777856

FEATURE

- Auto & Manual Ranging.
- Auto Power Off.
- Non-Contact Voltage Detector.
- Relative Measurement.

SPECIFICATIONS

AC Voltage 750V	DC Voltage 1000V	AC Current 1000A
DC Current 1000A	Resistance 60MΩ	Capacitance 100mF
Frequency 1000Hz	Display Counts 6000	Jaw Opening 40mm/1.6"
Continuity <50Ω		

CONTENTS



238×92×50mm
9.37"×3.6"×1.9"
386g/0.85lb



1×9V 6F22
Battery



ACCESSORIES

Test Leads
Carry bag
Battery



Calibration
Certificate



Quick Start
Guide

PACKAGING INFORMATION



Color Box
L130×W63×H255mm



Carton Box
53×34×28.5mm



X 20PCS



MAIN APPLICATIONS



INDUSTRIAL

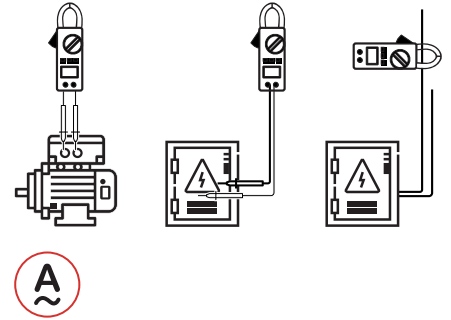

**HIGH SENSITIVITY
AC LEAKAGE CLAMP METER
MS2006B**

SKU NO.: MS2006BCBGLO
UPC CODE: 810053672532
EAN CODE: 8435394778174

FEATURE

- Auto Power Off.
- Data Hold.
- Low Battery Display.

SPECIFICATIONS

AC Current
60A

Display Counts
2000

Jaw Opening
31mm/1.2"

CONTENTS



176×59×28mm
6.9"×2.3"×1.1"
150g/0.33lb



2×1.5V AAA
Batteries



Carry bag
Battery

ACCESSORIES



Calibration
Certificate



Quick Start
Guide

PACKAGING INFORMATION



Color Box
L75×W45×H190mm



Carton Box
45×33×29.5cm



X 50PCS



MAIN APPLICATIONS

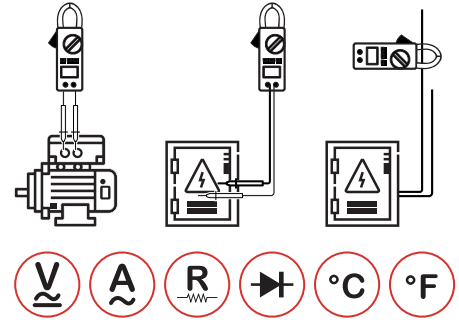

AC LEAKAGE CLAMP METER
MS2016A

SKU NO.: MS2016ACBGLO
UPC CODE: 810053675052
EAN CODE: 8435394783062

FEATURE

- Auto Ranging.
- Auto Power Off.
- True RMS For AC Voltage.
- Low Pass Filter Function (50/60Hz).

SPECIFICATIONS

AC Voltage 600V	DC Voltage 600V	AC Current 150A
Resistance 40MΩ	Capacitance 40mF	Jaw Opening 30mm/1.2"
Display Counts 4000	Temperature -20°C~1000°C/-4°F~1832°F	

CONTENTS



213×62×38mm
8.39"×2.44"×1.5"
238g/0.52lb



2×1.5V AAA
Batteries



ACCESSORIES

Test Leads
K-type thermocouple
Carry bag
Battery



Calibration
Certificate



Quick Start
Guide

PACKAGING INFORMATION



Color Box
L105×W55×H235mm



Carton Box
50×30.5×23cm



X 20PCS



MAIN APPLICATIONS

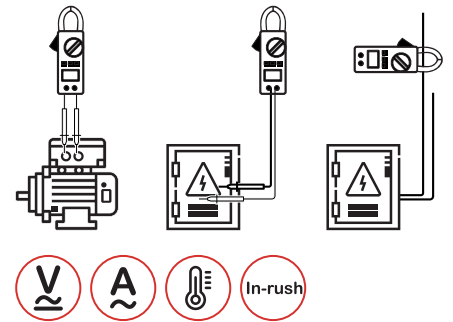
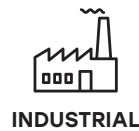
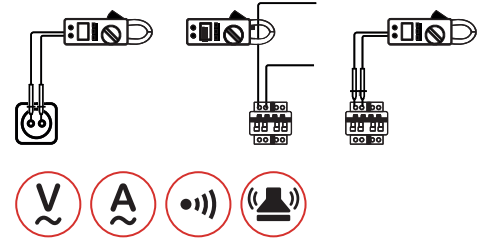

SINGLE PHASE POWER CLAMP METER
MS2225A

SKU NO.: MS2225ACBGLO
UPC CODE: 810053674680
EAN CODE: 8435394779744

FEATURE

- Auto & Manual Ranging.
- Auto Power Off.
- True Root Mean Square.
- Diode Open voltage 3.2V.

SPECIFICATIONS

AC Voltage 750V	DC Voltage 1000V	AC Current 1000A
Resistance 60MΩ	Capacitance 1000mF	Continuity <50Ω
Frequency 10kHz	Display Counts 6000	Jaw Opening 40mm/1.6"

CONTENTS



250×98×53mm
9.84"×3.78"×2.09"
450g/0.99lb



1×9V 6F22
Battery



ACCESSORIES

Test Leads
Carry bag
Battery



Calibration
Certificate

Alligator clip
(option)



Quick Start
Guide

PACKAGING INFORMATION



Color Box
L130×W63×H255mm



Carton Box
53×34×28.5mm



X 20PCS



MAIN APPLICATIONS

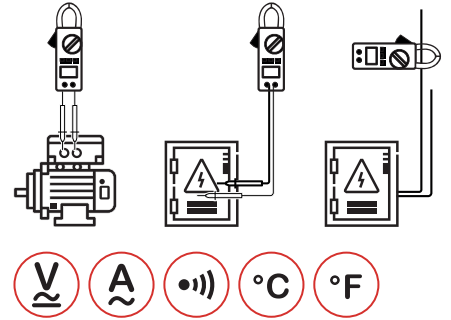

DIGITAL AC CLAMP METER
MS2601

SKU NO.: MS2601CBGLO
UPC CODE: 810053674215
EAN CODE: 8435394779287

FEATURE

- Auto & Manual Ranging.
- Auto Power Off.
- Non-Contact Voltage Detector.
- Diode Open Voltage 3.2V.

SPECIFICATIONS

AC Voltage 600V	DC Voltage 600V	AC Current 200A
Resistance 60MΩ	Capacitance 60mF	Frequency(A/V) 60Hz/60MHz
Display counts 6000	Jaw opening 12mm/0.5"	Continuity <50Ω
Temperature -20°C~400°C/-4°F~752°F		

CONTENTS



201×65×43mm
7.7"×2.6"×1.7"
265g/0.58lb



1×9V 6F22
Battery



ACCESSORIES

Test Leads
K type thermocouple
Carry bag
Battery



Calibration
Certificate



Quick Start
Guide

PACKAGING INFORMATION



Color Box
L172×W80×H255mm



Carton Box
53×44.5×37cm



X 20PCS

AC LINE SPLITTERS

EU TYPE | UK TYPE





AC LINE SPLITTER

MS922D

SKU NO.: MS922DCBGLO
 UPC CODE: 810053675397
 EAN CODE: 8435394783437

FEATURE

- Allows for Easy AC Current Measurements Using a Clamp Meter on 2 or 3 Wire Power Cords.
- Voltage Check Sockets for Easy Power Calculations.

SPECIFICATIONS

AC Voltage
250V

AC Current
15A

MAIN APPLICATIONS

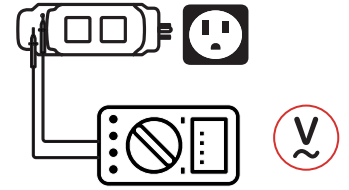
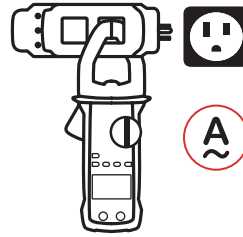

CONTENTS



200x57x48mm
 7.8"x2.2"x2.9"
 140g/0.3lb



Calibration Certificate



Quick Start Guide

PACKAGING INFORMATION



Color Box
 L85xW65xH230mm



Carton Box
 48x34.5x36.5cm



X 40PCS



MAIN APPLICATIONS

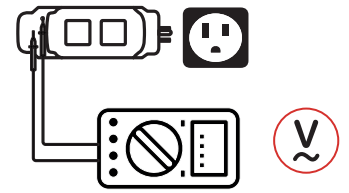
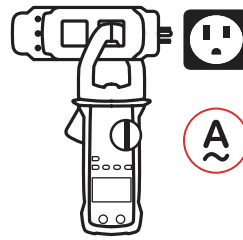

CONTENTS



173×57×48mm
6.8"×2.2"×1.9"
131g/0.29lb



Calibration Certificate



Quick Start Guide

PACKAGING INFORMATION



Color Box
L85×W65×H230mm



Carton Box
48×34.5×36.5cm



X 40PCS

AC LINE SPLITTER

MS922E

SKU NO.: MS922ECBGLO
UPC CODE: 810053675403
EAN CODE: 8435394783444

FEATURE

- Allows for Easy AC Current Measurements Using a Clamp Meter on 2 or 3 Wire Power Cords.
- Voltage Check Sockets for Easy Power Calculations.

SPECIFICATIONS

AC Voltage
250V

AC Current
15A

ELECTRICAL TESTERS

NON CONTACT VOLTAGE TESTER
TWO POLE VOLTAGE TESTER





MAIN APPLICATIONS

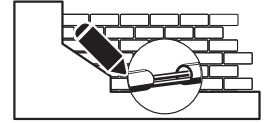

NON CONTACT AC VOLTAGE DETECTOR
MS8900

SKU NO.: MS8900CBGLO
UPC CODE: 810053672723
EAN CODE: 8435394778365

FEATURE

- Sound and Light Instruction.
- Double Molded Case.
- Operating Temperature 0°C~50°C.

SPECIFICATIONS

AC Voltage 100~240V	Frequency 50Hz~60Hz	Humidity 85%RH
-------------------------------	-------------------------------	--------------------------

CONTENTS



157×24×20mm
6.18"×0.94"×0.78"
42g/0.09lb



2×1.5V AAA
Batteries



ACCESSORIES

Battery



Calibration
Certificate



Quick Start
Guide

PACKAGING INFORMATION



Color Box
L82×W40×H184mm



Carton Box
39×22×35.5cm



X 40PCS



MAIN APPLICATIONS



DOMESTIC

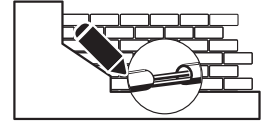

INDUSTRIAL



NON CONTACT AC VOLTAGE DETECTOR
MS8900A

SKU NO.: MS8900ACBGLO
UPC CODE: 810053673041
EAN CODE: 8435394778778

FEATURE

- Sound and Light Instruction.
- Double Molded Case.
- Operating Temperature 0°C~50°C.

SPECIFICATIONS

AC Voltage 90~1000V	Frequency 50Hz~60Hz	Humidity 85%RH
Altitude <2000m		

CONTENTS



157×24×20mm
6.18"×0.94"×0.78"
42g/0.09lb



2×1.5V AAA
Batteries



ACCESSORIES

Battery



Calibration
Certificate



Quick Start
Guide

PACKAGING INFORMATION



Color Box
L82×W40×H184mm



Carton Box
39×22×35.5cm



X 40PCS



MAIN APPLICATIONS

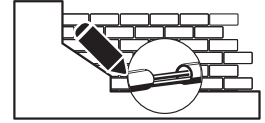

NON CONTACT AC VOLTAGE DETECTOR
MS8902A

SKU NO.: MS8902ACBGLO
 UPC CODE: 810053672730
 EAN CODE: 8435394778372

FEATURE

- Sound and Light Instruction.
- Double Molded Case.
- Operating Temperature 0°C~50°C.

SPECIFICATIONS

AC Voltage 12~1000V	Frequency 50Hz~500Hz	Humidity 85%RH
Altitude <2000m		

CONTENTS



157×24×20mm
 6.18"×0.94"×0.78"
 42g/0.09lb



2×1.5V AAA
 Batteries



ACCESSORIES

Battery



Calibration
 Certificate



Quick Start
 Guide

PACKAGING INFORMATION



Color Box
 L82×W40×H184mm



Carton Box
 39×22×35.5cm



X 40PCS



MAIN APPLICATIONS



DOMESTIC

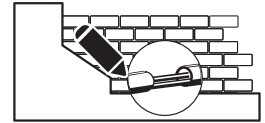

INDUSTRIAL



NON CONTACT AC VOLTAGE DETECTOR
MS8902B

SKU NO.: MS8902BCBGLO
UPC CODE: 810053674505
EAN CODE: 8435394779577

FEATURE

- Sound and Light Instruction.
- Double Molded Case.
- Operating Temperature 0°C~50°C.

SPECIFICATIONS

AC Voltage
20~1000V

Frequency
50Hz~500Hz

Humidity
85%RH

Altitude
<2000m

CONTENTS



157×24×20mm
6.18"×0.94"×0.78"
42g/0.09lb



1×12V A23S
Battery



ACCESSORIES

Battery



Calibration
Certificate



Quick Start
Guide

PACKAGING INFORMATION



Color Box
L82×W40×H184mm



Carton Box
39×22×35.5cm



X 40PCS



MAIN APPLICATIONS



DOMESTIC

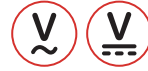
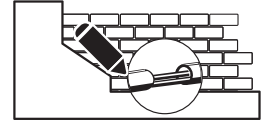

INDUSTRIAL



VOLTAGE TESTER

MS8922A

SKU NO.: MS8922ACBGLO
 UPC CODE: 810053674529
 EAN CODE: 8435394779591

FEATURE

- Ergonomic Design That Facilitates Its Use.
- Operation Time Maximum 30s.
- Recovery Time 10 Minutes.

SPECIFICATIONS

AC Voltage
400V

DC Voltage
400V

Frequency
50Hz/60Hz

Altitude
<2000m

CONTENTS



223×40×32mm
 8.78"×1.57"×1.26"
 98.5g/0.26lb



Calibration Certificate



Quick Start Guide

PACKAGING INFORMATION



Color Box
 L125×W40×H255mm



Carton Box
 53×25×27cm



X 20PCS



MAIN APPLICATIONS



DOMESTIC

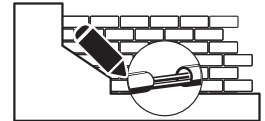

INDUSTRIAL



VOLTAGE TESTER WITH RCD
MS8922B

SKU NO.: MS8922BCBGLO
UPC CODE: 810053674536
EAN CODE: 8435394779607

FEATURE

- RCD Test Function.
- Operation Time Maximum 30s.
- Recovery Time 10 Minutes.
- Operation Temperature -10~55°C/14~131°F.

SPECIFICATIONS

AC Voltage
400V

DC Voltage
400V

Frequency
50Hz/60Hz

Altitude
<2000m

CONTENTS



223×40×32mm
8.78"×1.57"×1.26"
98.5g/0.26lb



Calibration Certificate



Quick Start Guide

PACKAGING INFORMATION



Color Box
L125×W40×H255mm



Carton Box
53×25×27cm



X 20PCS

CIRCUIT TESTERS

SOCKET TESTER | CIRCUIT BREAKER FINDER





MS5902RTD



MS5902RTE



MS5902RTF



MAIN APPLICATIONS



DOMESTIC

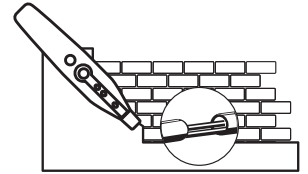
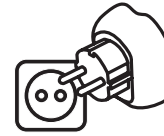

CONTENTS



MS5902R:
198×40×50mm
7.8"×1.57"×1.97"
126g/0.28lb

MS5902TD/TE:
71×64×55mm
2.8"×2.5"×2.16"
60g/0.13lb

MS5902TF:
82×42×32mm
3.2"×1.65"×1.26"
35g/0.1lb



Carry bag

ACCESSORIES



1×9V 6F22
Battery



Calibration
Certificate



Quick Start
Guide

CIRCUIT BREAKER FINDER

MS5902RT

SKU NO.	MS5902RTDCBGLO	MS5902RTECBGLO	MS5902RTFCBGLO
UPC CODE	810053672877	810053675106	810053674727
EAN CODE	8435394778556	8435394783093	8435394779782

FEATURE

- Socket Tester and Circuit Breaker Finder.
- Sound and Light Signals.
- Professional Reference.

SPECIFICATIONS

AC Voltage(TD)
230V

AC Voltage(TE)
230V

AC Voltage(TF)
120V

PACKAGING INFORMATION



Color Box
L130×W63×H255mm



Carton Box
53×34×28.5cm



X 20PCS



MS5905TD



MS5905TE



MAIN APPLICATIONS



DOMESTIC

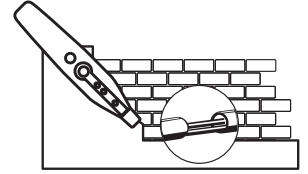
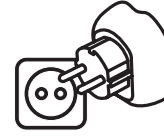

CONTENTS



MS5905R:
177×46×31mm
6.97"×1.81"×1.22"
130g/0.29lb

MS5905TD/TE:
71×64×55mm
2.8"×2.5"×2.16"
63g/0.14lb



ACCESSORIES

Carry bag
Battery



1×9V 6F22
Battery



Calibration
Certificate



Quick Start
Guide

CIRCUIT BREAKER FINDER with NCV
MS5905RT

SKU NO.	MS5905RTDCBGLO	MS5905RTECBGLO
UPC CODE	810053675120	810053673126
EAN CODE	8435394783116	8435394778853

FEATURE

- Socket Tester and Circuit Breaker Finder.
- Sound and Light Signals.
- Professional Reference.

SPECIFICATIONS

AC Voltage(TD) 230V	AC Voltage(TE) 230V
-------------------------------	-------------------------------

PACKAGING INFORMATION



Color Box
L130×W63×H255mm



Carton Box
53×34×28.5mm



X 20PCS



MAIN APPLICATIONS



DOMESTIC

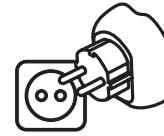

MS6860D



MS6860E

SOCKET TESTER

MS6860

SKU NO.	MS6860DCBGLO	MS6860ECBGLO
UPC CODE	810053674369	810053675281
EAN CODE	8435394779430	8435394783307

FEATURE

- Reliable and Easy to Use Modern, Ergonomic Design with Unique Soft Finger Grip Compact, Durable-Designed to Safety Standard EN61010.

SPECIFICATIONS

AC Voltage(MS6860D)
230V

AC Voltage(MS6860E)
230V

CONTENTS



68×60×56mm
2.67"×2.36"×2.2"
60g/0.13lb



Calibration Certificate



Quick Start Guide

PACKAGING INFORMATION



Color Box
L88×W65×H100mm



Carton Box
34.5×22×38cm



X 40PCS

CIRCUIT ANALYZERS

MOTOR & PHASE ROTATION INDICATOR



MASTECH MS5900
MOTOR&PHASE ROTATION INDICATOR

U L1/A V L2/B W L3/C
CAT III 600V

SENSOR M SENSOR

L R

ON

○ OFF NOT DEFINED ⚠

⊗ ON L1=A, L2=B, L3=C

DISPLAY	⊗	⊙	L1	L2	L3
Rotat.Right	⊙	⊗	⊗	⊗	⊗
Rotat.Left	⊗	⊙	⊙	⊙	⊙
L1 MISSING	⊙	⊙	⊙	⊙	⊙
L2 MISSING	⊙	⊙	⊙	⊙	⊙
L3 MISSING	⊙	⊙	⊙	⊙	⊙

Un=400/230V AC Ume=1...400V AC fn=2...400Hz
L1=L2=L3 3.5mA/400V CONTINUOUS OPERATION
IEC 61557-7

MASTECH

L1/A U L2/B V L3/C W
CAT III 600V

SENSOR M SENSOR

L R

ON

MS5901
MOTOR & PHASE ROTATION INDICATOR

⊗ ON ⊙ OFF ⊙ NOT DEFINED

DISPLAY	⊗	⊙	L1/A	L2/B	L3/C
Rotat.Right	⊙	⊗	⊗	⊗	⊗
Rotat.Left	⊗	⊙	⊙	⊙	⊙
L1 MISSING	⊙	⊙	⊙	⊙	⊙
L2 MISSING	⊙	⊙	⊙	⊙	⊙
L3 MISSING	⊙	⊙	⊙	⊙	⊙

Un=400/230V AC Ume=1...400V AC fn=2...400Hz
L1=L2=L3 3.5mA/400V CONTINUOUS OPERATION



MAIN APPLICATIONS

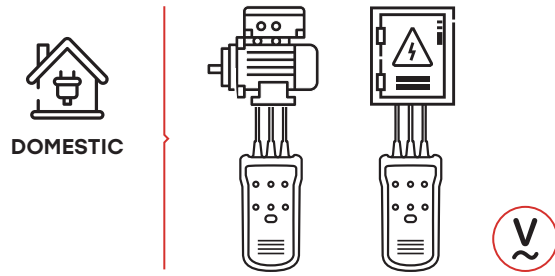

CONTENTS

- 130x72x32mm
5.1"x2.8"x1.3"
193g/0.43lb
- 1x9V 6F22
Battery
- Test alligator clips
Carry bag
Battery
- Calibration
Certificate
- Quick Start
Guide

MOTOR & PHASE ROTATION INDICATOR
MS5900

SKU NO.: MS5900CBGLO
UPC CODE: 810053672006
EAN CODE: 8435394777733

FEATURE

- Motor & phase rotation tester.
- Led light signals.
- Operating Altitude 2000m.
- Pollution Degree 2.

SPECIFICATIONS

AC Voltage() 120~400V	Frequency 2~400Hz
---------------------------------	-----------------------------

PACKAGING INFORMATION

- Color Box**
L168xW64xH238mm
- Carton Box**
49.5x37x35.5cm
- X 20PCS**



MAIN APPLICATIONS

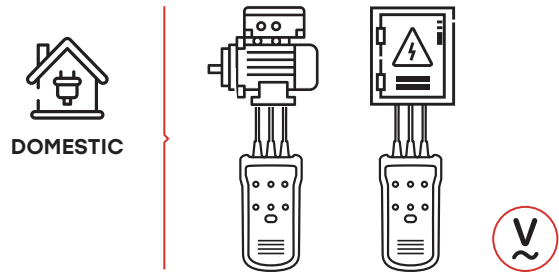

CONTENTS



130x72x32mm
5.1"x2.8"x1.3"
193g/0.43lb



1x9V 6F22
Battery



ACCESSORIES

Test alligator clips
Carry bag
Battery



Calibration
Certificate



Quick Start
Guide

MOTOR & PHASE ROTATION INDICATOR
MS5901

SKU NO.: MS5901CBGLO
UPC CODE: 810053672921
EAN CODE: 8435394778655

FEATURE

- Motor & phase rotation tester.
- Led light signals.
- Operating Altitude 2000m.
- Pollution Degree 2.

SPECIFICATIONS

AC Voltage 120~400V	Frequency 2~400Hz
-------------------------------	-----------------------------

PACKAGING INFORMATION



Color Box
L168xW64xH238mm



Carton Box
51x36x36cm



X 20PCS

WIRE & CABLE TESTERS

NETWORK CABLE TESTER | MULTI-FUNCTIONS CABLE TRACKER |
ADVANCED CABLE LOCATOR





MAIN APPLICATIONS

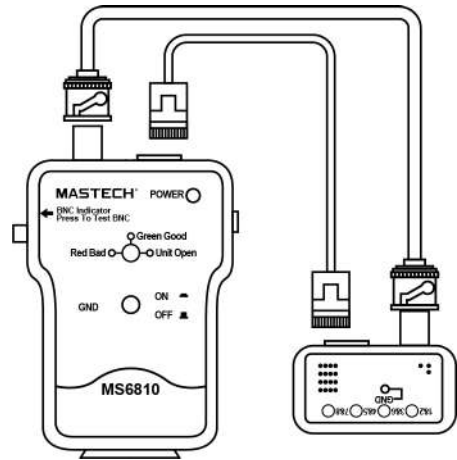

NETWORK CABLE TESTER
MS6810

SKU NO.: MS6810CBGLO
UPC CODE: 810053674345
EAN CODE: 8435394779416

FEATURE

- Widely Used For Coaxial Cable (BNC), UTP And STP Cable. It Can Automatically Check For Open Circuits, Shorts, Miswired, And Reversals.

SPECIFICATIONS

Distance
200m(max)

CONTENTS



153×74×31mm
6.0"×2.9"×1.2"
120g/0.26lb



1×9V 6F22
Battery



Carry bag
Battery

ACCESSORIES



Calibration
Certificate



Quick Start
Guide

PACKAGING INFORMATION



Color Box
L90×W40×H165mm



Carton Box
42.5×35×29cm



X 60PCS



NETWORK CABLE TESTER
MS6811

SKU NO.: MS6811CBGLO
UPC CODE: 810053672624
EAN CODE: 8435394778266

FEATURE

- Tests for Open Circuits, Shorts, Miswires, Reversals, and Split Pairs.
- DEBUG Quickly Identifies Which Cable Pairs Have A Specific Wiring Fault.

SPECIFICATIONS

Distance
200m(max)

MAIN APPLICATIONS

Fault details

Fig.1 SPLIT PAIRS

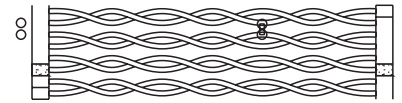

Fig.2 SHORT

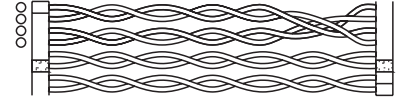

Fig.3 MISWIRE

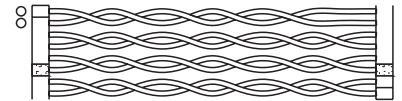
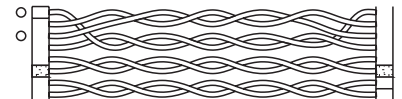

Fig.4 REVERSED



CONTENTS



125×55×30mm
4.9"×2.2"×1.2"
106g/0.23lb



1×6V 4LR44/
4AG13 Battery



Carry bag
Battery

ACCESSORIES



Calibration
Certificate



Quick Start
Guide

PACKAGING INFORMATION



Color Box
L90×W40×H165mm



Carton Box
42.5×35×29cm



X 60PCS



MAIN APPLICATIONS

Fig.1 SHORT



Fig.2 MISWIRE



Fig.3 REVERSED



Fig.4 SPLIT PAIRS



MULTI-FUNCTIONS CABLE TRACKER
MS6813

SKU NO.: MS6813CBGLO
UPC CODE: 810053672976
EAN CODE: 8435394778709

FEATURE

- Multifunction.
- Cable tester and tracker.
- State of the telephone lines.
- Small size ideal for transport.

SPECIFICATIONS

Receive Frequency
100Hz~300kHz

Send Tone Frequency
1.5kHz

CONTENTS



206×84×55mm
8.1"×3.3"×2.1"
330g/0.72lb



2×9V 6F22
Batteries



ACCESSORIES

Carry bag
Battery



Calibration
Certificate



Quick Start
Guide

PACKAGING INFORMATION



Color Box
L172×W80×H255mm



Carton Box
46×27×37cm



X 10PCS



MAIN APPLICATIONS

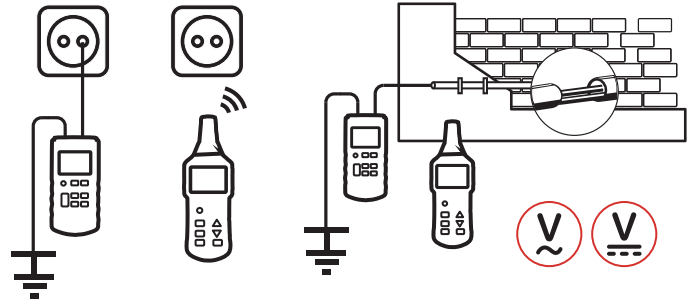

CONTENTS



Transmitter:
190×89×42.5mm
7.48"×3.5"×1.67"
420g/0.92lb



Receiver:
241.5×78×38.5mm
9.5"×3"×1.5"
350g/0.77lb



ACCESSORIES

Test leads
Test probe
Alligator clip
Grounding rod
Carry bag
Battery



1×9V 6F22 Battery/
6×1.5V AAA
Batteries



Calibration
Certificate



Quick Start
Guide

ADVANCED WIRE TRACKER
MS6818

SKU NO.: MS6818CBGLO
UPC CODE: 810053672204
EAN CODE: 8435394777924

FEATURE

- Track Cables In The Wall or Earth.
- One or Dual-pole Application.
- Adjustable Sensitivity In Transmitter and Receiver.

SPECIFICATIONS

AC Voltage
12~400V

DC Voltage
12~400V

Output Signal
125kHz

Display Counts
2000

PACKAGING INFORMATION



Color Box
L200xW85xH280mm



Carton Box
44.5x32.5x42cm



X 10PCS

LCR METERS

DIGITAL LCR METER | SMART SMD TESTER







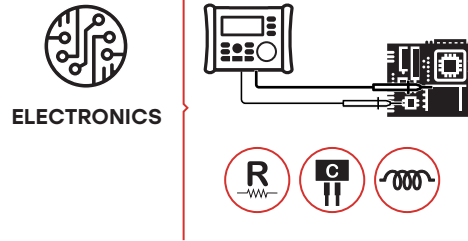

MAIN APPLICATIONS



CONTENTS

-  224x172x58mm
8.8"x6.8"x2.3"
841g/1.85lb
-  8x1.5 AA Batteries
-  **ACCESSORIES**
Kelvin test clip
SMD test probe
IR data line
Software CD
Battery
-  Calibration Certificate
-  Quick Start Guide
- External power supply (option)

DIGITAL LCR METER WITH USB INTERFACE
MS5308

SKU NO.: MS5308CBGLO
UPC CODE: 810053673102
EAN CODE: 8435394778839



FEATURE

- Auto & Manual Ranging.
- Auto Power off.
- LCR smart check and measurement.
- DCR mode.

SPECIFICATIONS

Resistance 200Ω	Capacitance 2000μF	LCR 2000H
---------------------------	------------------------------	---------------------

PACKAGING INFORMATION

-  **Color Box**
L320xW125xH255mm
-  **Carton Box**
52x33.5x29cm
-  **X 4PCS**



MAIN APPLICATIONS

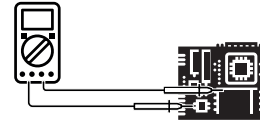

CONTENTS



189×91×31.5mm
7.4"×3.6"×1.2"
240g/0.52lb



1×9V 6F22
Battery



ACCESSORIES

Test Leads
Carry bag
Battery



Calibration
Certificate



Quick Start
Guide

DIGITAL LCR METER

MS6013

SKU NO.: MS6013CBGLO
UPC CODE: 810053674222
EAN CODE: 8435394779294

FEATURE

- Zero Adjustment approx. ± 20pF.
- Input Jacks.
- High Accuracy in Measuring.
- Low Battery Display.

SPECIFICATIONS

Capacitance
200pF~20mF

Display Counts
2000

PACKAGING INFORMATION



Color Box
L165×W70×H225mm



Carton Box
47×37.5×35.5cm



X 20PCS



MAIN APPLICATIONS



ELECTRONICS

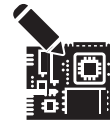

SMART SMD TESTER (R/C)
MS8910

SKU NO.: MS8910CBGLO
UPC CODE: 810053672747
EAN CODE: 8435394778389

FEATURE

- Auto Ranging.
- Auto Power Off.
- Data Hold.
- Low Battery Display.

SPECIFICATIONS

Resistance
30MΩ

Capacitance
30mF

Display Counts
3000

Continuity
30Ω

CONTENTS



175x32x20mm
6.89"x1.26"x0.79"
48g/0.10lb



1x3V CR2032
Battery



ACCESSORIES

Spare test pin
Battery



Calibration
Certificate



Quick Start
Guide

PACKAGING INFORMATION



Color Box
L57xW29xH203mm



Carton Box
44x32x31.5cm



X 100PCS



MAIN APPLICATIONS

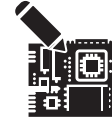

SMART SMD TESTER (R/C/L)
MS8911

SKU NO.: MS8911CBGLO
UPC CODE: 810053674512
EAN CODE: 8435394779584

FEATURE

- Auto Ranging.
- Auto Power Off.
- Data Hold.
- Low Battery Display.

SPECIFICATIONS

Resistance 20MΩ	Capacitance 6mF	Inductance 200H
Display Counts 6000		

CONTENTS



186×35×23.6mm
7.3"×1.38"×0.93"
90g/0.2lb



1×3V CR2450
Battery



ACCESSORIES

Spare test pin
Battery



Calibration
Certificate



Quick Start
Guide

PACKAGING INFORMATION



Color Box
L57×W29×H203mm



Carton Box
44×32×31.5cm



X 100PCS



MAIN APPLICATIONS

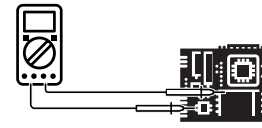

CONTENTS



189×91×31.5mm
7.4"×3.6"×1.2"
240g/0.52lb



1×9V 6F22
Battery



ACCESSORIES

Test Leads



Calibration
Certificate



Quick Start
Guide

DIGITAL LCR METER

MY6243

SKU NO.: MY6243CBGLO
UPC CODE: 810053672754
EAN CODE: 8435394778396

FEATURE

- Input Jacks.
- High Accuracy in Measuring.
- Low Battery Display.

SPECIFICATIONS

Capacitance
200µF

Inductance
2H

Display Counts
2000

PACKAGING INFORMATION



Color Box
L165×W70×H225mm



Carton Box
47×37.5×35.5cm



X 20PCS

EARTH RESISTANCE

EARTH RESISTANCE CLAMP METER | EARTH RESISTANCE TESTER
ADVANCED EARTH RESISTANCE TESTER





MAIN APPLICATIONS



DOMESTIC

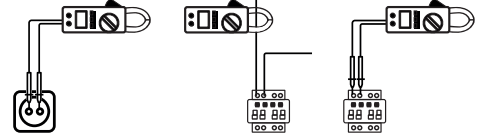

INDUSTRIAL

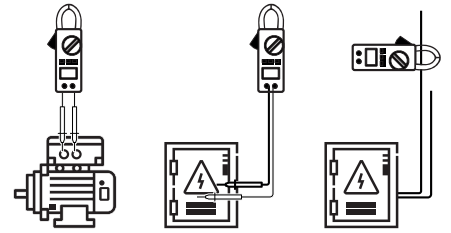

EARTH RESISTANCE CLAMP METER
MS2301

SKU NO.: MS2301CBGLO
UPC CODE: 810053674208
EAN CODE: 8435394779270

FEATURE

- Auto & Manual Ranging.
- Logging and Recall 99 Groups.
- Setting Alarm Threshold in 1~100Ω.

SPECIFICATIONS

Resistance
1200Ω

AC Current
20A

Display Counts
9999

Jaw Opening
45mmx32mm/1.8"x1.3"

Data Logging
99 groups

CONTENTS



276x104x54mm
10.8"x4.33"x2.1"
1050g/2.31lb



1x9V Alkaline Battery



ACCESSORIES

Calibration loop of resistance (1Ω/5Ω/10Ω)
Carry case
Battery



Calibration Certificate



Quick Start Guide

PACKAGING INFORMATION



Color Box
L370xW140xH324mm



Carton Box
58x39x35cm



X 4PCS



MAIN APPLICATIONS

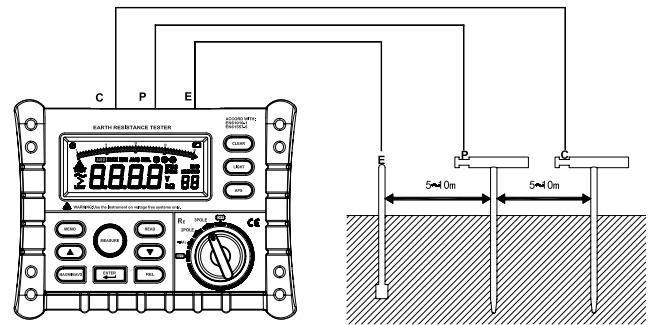
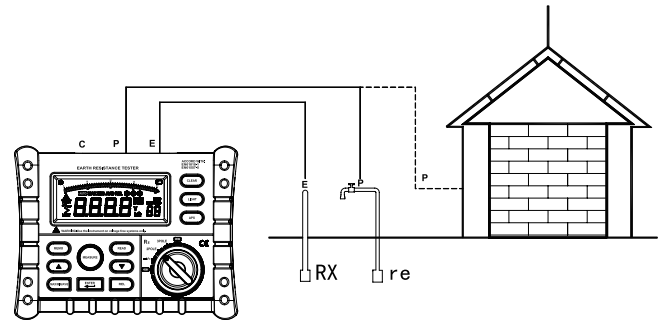

EARTH RESISTANCE TESTER
MS2302

SKU NO.: MS2302CBGLO
UPC CODE: 810053672150
EAN CODE: 8435394777870

FEATURE

- Auto & Manual Ranging.
- Auto Power Off.
- Segments Bar Graph.
- MAX/MIN/AVG.

SPECIFICATIONS

Earth Voltage AC 0~200V	Earth Resistance 0.01~4000Ω
-----------------------------------	---------------------------------------

CONTENTS

- | | | | |
|--|---|--|-------------------------|
| | 330×265×125mm
13"×10.4"×4.9"
900g/1.98lb | | 6×1.5V AA Batteries |
| | Test leads (Red-15m/
Green-10m/Black-5m)
Wrapping bag
Auxiliary earth bar
Battery | | Calibration Certificate |
| | | | Quick Start Guide |

PACKAGING INFORMATION

- | | | |
|--|--------------------------------------|--------|
| | Color Box
L325×W125×H255mm | |
| | Carton Box
52×33.5×29cm | X 4PCS |



ADVANCED EARTH RESISTANCE TESTER
MS2308

SKU NO.: MS2308CTGLO
UPC CODE: 810053676790
EAN CODE: 8435394785318

FEATURE

- Auto Power Off.
- Alarming indicator for limit-value measurement.
- AVG.
- Compensation Resistance.

SPECIFICATIONS

3 Pole & 4 Pole Earthing-Resistance Test 0.02Ω~300kΩ		
2 Pole R (AC) 0.02Ω~300kΩ	2 Pole R (DC) 0.02Ω~3kΩ	Soil Resistivity ρ 0.02~1000

MAIN APPLICATIONS

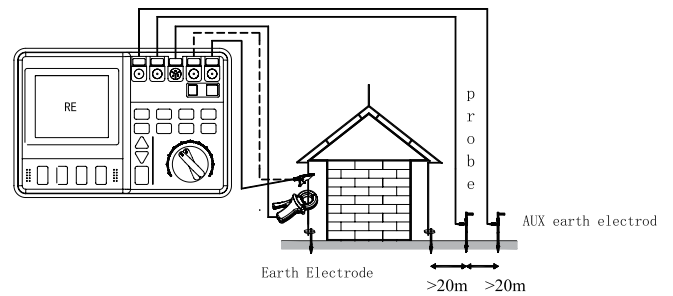
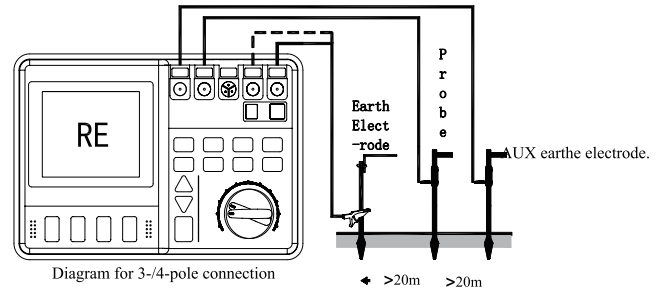

CONTENTS



284×230×125mm
11.2"×9.1"×4.9"
2.5kg/5.5lb



6×1.5V AA Batteries/
Ni~MH Recharge Battery, 7.2V



ACCESSORIES

- Test wire
- Alligator clip
- Auxiliary earth bar
- Power cord
- Current transformer φ51mm
- Current clamp cable
- Carry bag
- Software CD
- USB interface cable
- Battery



Calibration Certificate



Quick Start Guide

- Rechargeable Ni-MH battery (optional)
- Charger (optional)

PACKAGING INFORMATION



Carton Box
40×17.5×31.5cm



X 1PCS

INSULATION TESTERS

DIGITAL INSULATION TESTER |

ADVANCED HIGH VOLTAGE INSULATION TESTER





MAIN APPLICATIONS

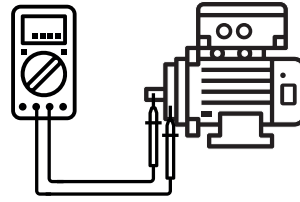

CONTENTS



192×122×55mm
7.48"×4.7"×2.2"
545g/1.3lb



6×1.5V AA
Batteries



ACCESSORIES

Test Leads
Test Clips
Screwdriver
Soft Case
Carrying Case
Battery



Calibration
Certificate



Quick Start
Guide

DIGITAL INSULATION TESTER
MS5201

SKU NO.: MS5201CBGLO
UPC CODE: 810053672884
EAN CODE: 8435394778617

FEATURE

- Data Hold.
- Low Battery Display.
- Constant Measuring Lock.

SPECIFICATIONS

AC Voltage 700V	DC Voltage 1000V	Resistance 2000MΩ
Display Counts 2000	Continuity <50Ω	

PACKAGING INFORMATION



Color Box
L370×W140×H324mm



Carton Box
58×39×35cm



X 4PCS



MAIN APPLICATIONS

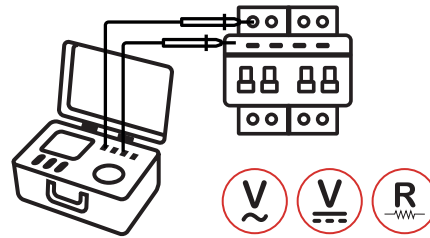

CONTENTS



284×230×125mm
11.2"×9.1"×4.9"
2426g/5.34lb



6×LR14 Batteries/
6×1.2V AA Batteries



ACCESSORIES

Tester probes leads 3m (Red/Black/Blue)
Crocodile clips (Red/Black/Blue)
Temperature Sensor
USB data line (1m)
Data analysis software CD
Instrument backpack
Battery

Charger:
Input Voltage
100V~240V

Rechargeable battery pack(for charging Ni-Hy battery)(optional)
AC charger (optional)



Calibration Certificate



Quick Start Guide

ADVANCED HIGH VOLTAGE INSULATION TESTER
MS5215

SKU NO.: MS5215CBGLO
UPC CODE: 810053672914
EAN CODE: 8435394778648

FEATURE

- Broad Range Of Testing Voltage.
- Insulation Diagnosis.
- Large Storage Memory.
- Clear Display.

SPECIFICATIONS

AC Voltage
50~750V

DC Voltage
50~1000V

Resistance
0.01MΩ~5TΩ

Temperature
-10°C~70°C

PACKAGING INFORMATION



Color Box
L400×W175×H315mm



Carton Box
42×37×34cm



X 2PCS

PAT TESTER

SAFETY PAT PLUS TESTER



CLASS I CLASS II DATA RECALL CORD / EXT
A B C



MAIN APPLICATIONS

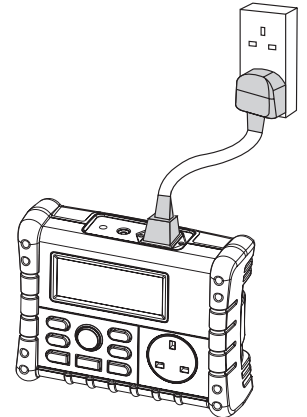
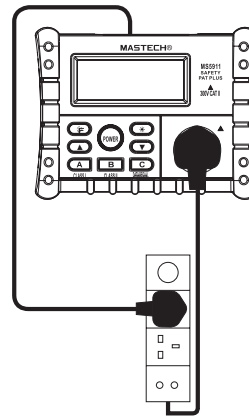
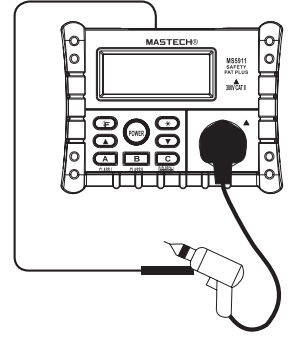
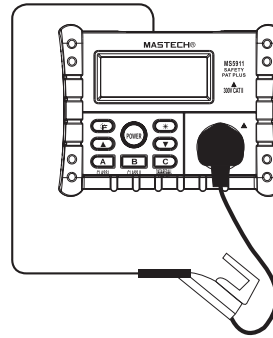

SAFETY PAT PLUS TESTER
MS5911

SKU NO.: MS5911CBGLO
UPC CODE: 810053675137
EAN CODE: 8435394783123

FEATURE

- Safety CLASS I - Grounding/Insulation Resistance/Leakage Current
- Safety CLASS II - Insulation Resistance/Leakage Current

SPECIFICATIONS

DC Output 250/500V	Resistance 20MΩ
------------------------------	---------------------------

CONTENTS



204x155x76mm
7.8"x6.1"x3"
1270g/2.8lb



DV12V /
8x1.5V AA
Batteries



ACCESSORIES

- Main test cord
- Alligator clip test cord
- Probe
- Rugged padded carrying case
- Battery



Calibration Certificate



Quick Start Guide

DC power adapter (optional)

PACKAGING INFORMATION



Color Box
L325xW125xH255mm



Carton Box
52x33.5x29cm



X 4PCS

THERMOMETERS

DIGITAL THERMOMETER | DIGITAL THERMO-HYGROMETER
NON-CONTACT INFRARED THERMOMETER





MAIN APPLICATIONS

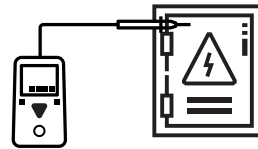
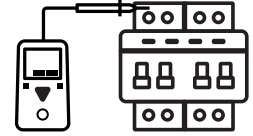
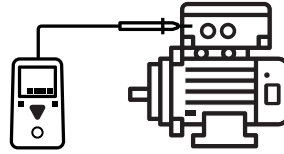

CONTENTS



125.5x72x27mm
5.6"x2.8"x1.0"
145g/0.30lb



1x9V 6F22
Battery



ACCESSORIES

K type thermocouple
Carry bag
Battery



Calibration
Certificate



Quick Start
Guide

DIGITAL THERMOMETER

MS6500

SKU NO.: MS6500CBGLO
UPC CODE: 810053673089
EAN CODE: 8435394778815

FEATURE

- Sample Rate 500mS.
- Display 2000 counts.
- Data Hold.
- K-Type Thermocouple.

SPECIFICATIONS

Celsius
-50°C~750°C

Fahrenheit
-58°F~1382°F

Display Counts
2000

PACKAGING INFORMATION



Color Box
L105xW40xH145mm



Carton Box
42x31.5x34cm



X 60PCS



MAIN APPLICATIONS

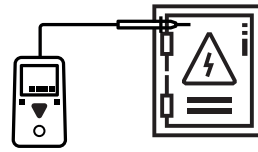
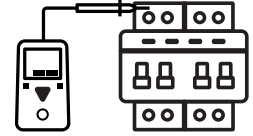
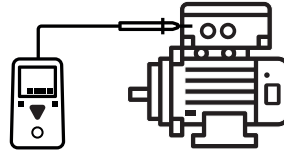

DIGITAL THERMOMETER
MS6511

SKU NO.: MS6511CBGLO
UPC CODE: 810053675243
EAN CODE: 8435394783246

FEATURE

- Auto Power Off.
- Data Hold.
- MAX/MIN/AVG.
- Low Battery Display.

SPECIFICATIONS

Type K, J, T, E	Channel TC
---------------------------	----------------------

CONTENTS



190×89×42mm
7.5"×3.5"×1.7"
350g/0.8lb



1×9V 6F22
Battery



K type thermocouple
Battery

ACCESSORIES



Calibration
Certificate



Quick Start
Guide

PACKAGING INFORMATION



Color Box
L165×W70×H225mm



Carton Box
47×37.5×35.5cm



X 20PCS



MAIN APPLICATIONS

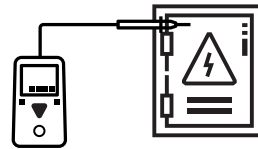
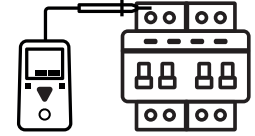
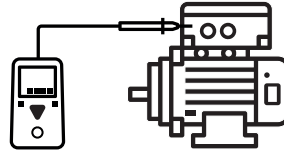

DIGITAL THERMOMETER
MS6512

SKU NO.: MS6512CBGLO
UPC CODE: 810053672945
EAN CODE: 8435394778679

FEATURE

- Auto Power Off.
- Data Hold.
- MAX/MIN/AVG.
- Low Battery Display.

SPECIFICATIONS

Type K, J, T, E	Channel T1/T2/T1-T2
---------------------------	-------------------------------

CONTENTS



190×89×42mm
7.5"×3.5"×1.7"
350g/0.8lb



1×9V 6F22
Battery



ACCESSORIES

K type thermocouple
Battery



Calibration
Certificate



Quick Start
Guide

PACKAGING INFORMATION



Color Box
L165×W70×H225mm



Carton Box
47×37.5×35.5cm



X 20PCS



MAIN APPLICATIONS

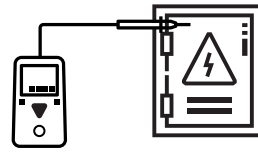
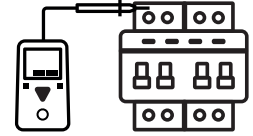
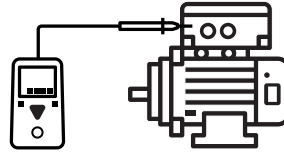

DIGITAL THERMOMETER
MS6513

SKU NO.: MS6513CBGLO
UPC CODE: 810053672044
EAN CODE: 8435394783253

FEATURE

- Auto Power Off.
- Data Hold.
- Memory Save Data.
- USB Interface.

SPECIFICATIONS

Type
K, J, T, E, R, S, N

Channel
TC

CONTENTS



190×89×42mm
7.5"×3.5"×1.7"
350g/0.8lb



1×9V 6F22
Battery



ACCESSORIES

K type thermocouple
USB interface cable
Software CD
Battery



Calibration
Certificate



Quick Start
Guide

PACKAGING INFORMATION



Color Box
L165×W70×H225mm



Carton Box
47×37.5×35.5cm



X 20PCS



MAIN APPLICATIONS

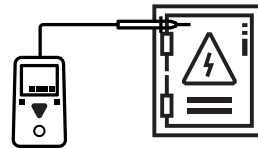
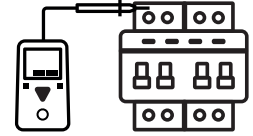
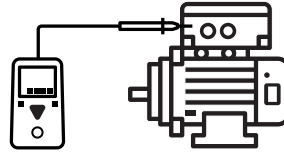

DIGITAL THERMOMETER

MS6514

SKU NO.: MS6514CBGLO
 UPC CODE: 810053672037
 EAN CODE: 8435394777764

FEATURE

- Auto Power Off.
- Data Hold.
- Memory Save Data.
- USB Interface.

SPECIFICATIONS

Type
K, J, T, E, R, S, N

Channel
T1/T2/T1-T2

CONTENTS



190×89×42mm
 7.5"×3.5"×1.7"
 350g/0.8lb



1×9V 6F22
 Battery



ACCESSORIES

K type thermocouple
 USB interface cable
 Software CD
 Battery



Calibration
 Certificate



Quick Start
 Guide

PACKAGING INFORMATION



Color Box
 L165×W70×H225mm



Carton Box
 47×37.5×35.5cm



X 20PCS



MAIN APPLICATIONS

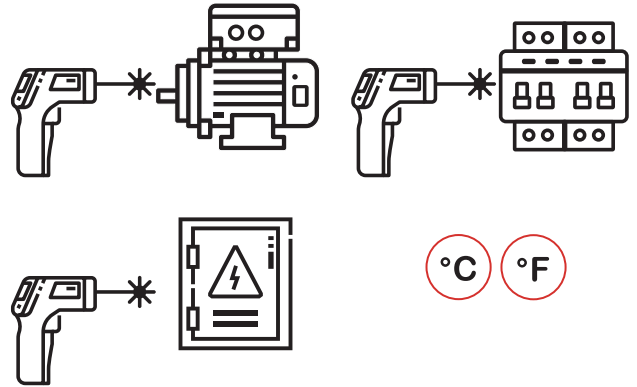

**INFRARED THERMOMETER
MS6522A**

SKU NO.: MS6522ACBGLO
UPC CODE: 810053674567
EAN CODE: 8435394779638

FEATURE

- Spectral Response 8-14 μm .
- Laser <math><1\text{mW}</math>/630-670nm.
- Response Time 1 Second.
- Relative Humidity 10%~90%

SPECIFICATIONS

Repeatability
 $\pm 0.1^{\circ}\text{C}$

Temperature
 $-20^{\circ}\text{C}\sim 300^{\circ}\text{C}/-4^{\circ}\text{F}\sim 572^{\circ}\text{F}$

Emissivity
0.95

CONTENTS

 143x99x47mm
5.6"x3.9"x1.85"
135g/0.3lb

 2x1.5V AAA
Batteries

 Battery
ACCESSORIES

 Calibration
Certificate

 Quick Start
Guide

PACKAGING INFORMATION

 **Color Box**
L125xW55xH183mm

 **Carton Box**
57.5x39.1x27.5cm

 **X 40PCS**



MAIN APPLICATIONS

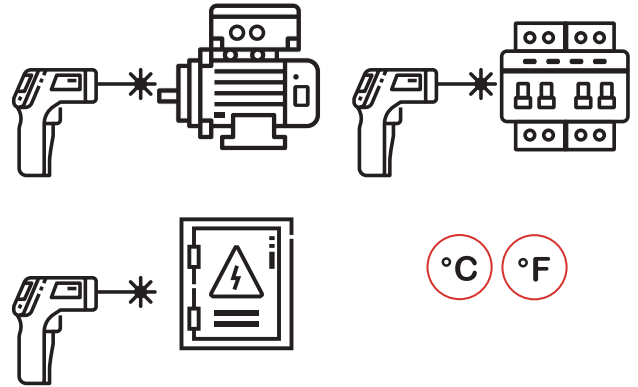

**INFRARED THERMOMETER
MS6522B**

SKU NO.: MS6522BCBGLO
UPC CODE: 810053672617
EAN CODE: 8435394778914

FEATURE

- Spectral Response 8-14 μm.
- Laser <1mW/630-670nm.
- Response Time 1 second.
- Relative Humidity 10%~90%

SPECIFICATIONS

Repeatability ±0.1°C	Temperature -20°C~500°C/-4°F~932°F
Emissivity 0.95	

CONTENTS

- 143x99x47mm
5.6"x3.9"x1.85"
135g/0.3lb
- 2x1.5V AAA Batteries
- Battery
- Calibration Certificate
- QSG Quick Start Guide

PACKAGING INFORMATION

- Color Box**
L125xW55xH183mm
- Carton Box**
57.5x39.1x27.5cm
- X 40PCS**



MAIN APPLICATIONS

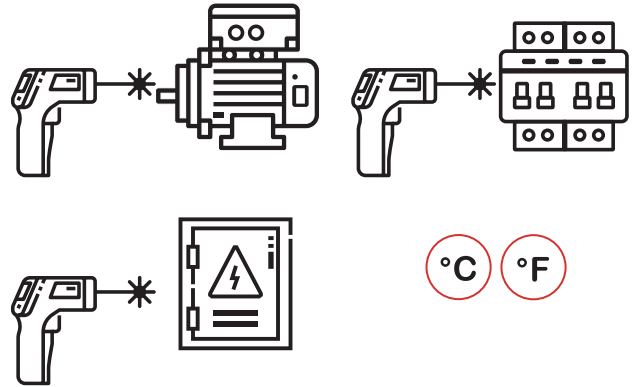

INFRARED THERMOMETER COLOR LCD
MS6531B

SKU NO.: MS6531BCBGLO
UPC CODE: 810053672969
EAN CODE: 8435394778693

FEATURE

- Color Display.
- Auto Power Off.
- Spectral Response 8-14 μm.
- Laser <1mW/630-670nm.

SPECIFICATIONS

IRT Temperature
-40°C~800°C/-40°F~1472°F

Repeatability
±0.1°C

Emissivity
0.10~1.00

CONTENTS



176×132×49mm
6.9"×5.2"×1.9"
223g/0.5lb



1×9V 6F22
Battery



ACCESSORIES

Carry bag
Battery



Calibration
Certificate



Quick Start
Guide

PACKAGING INFORMATION



Color Box
L126×W58×H210mm



Carton Box
44.5×34×28cm



X 20PCS



MAIN APPLICATIONS

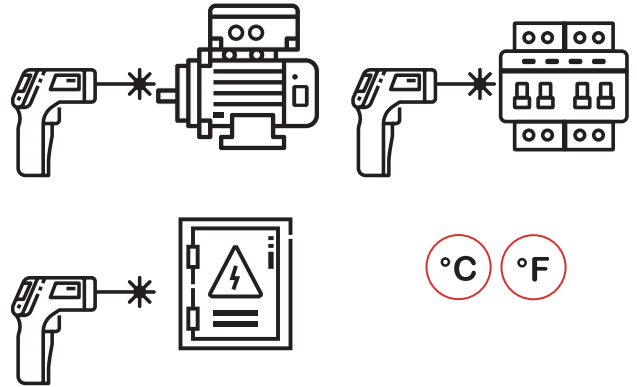

INFRARED THERMOMETER COLOR LCD
MS6531C

SKU NO.: MS6531CCBGLO
UPC CODE: 810053674284
EAN CODE: 8435394779355

FEATURE

- Color Display.
- Auto Power Off.
- Spectral Response 8-14 μm.
- Laser <1mW/630-670nm.

SPECIFICATIONS

IRT Temperature -40°C~800°C/-40°F~1472°F	Repeatability ±0.1°C
K-Type Temperature -40°C~1080°C/-40°F~1976°F	Emissivity 0.10~1.00

CONTENTS

- 176×132×49mm
6.9"×5.2"×1.9"
223g/0.5lb
- 1×9V 6F22 Battery
- K type thermocouple
Carry bag
Battery
- Calibration Certificate
- Quick Start Guide

PACKAGING INFORMATION

- Color Box**
L126×W58×H210mm
- Carton Box**
44.5×34×28cm
- X 20PCS**



MAIN APPLICATIONS

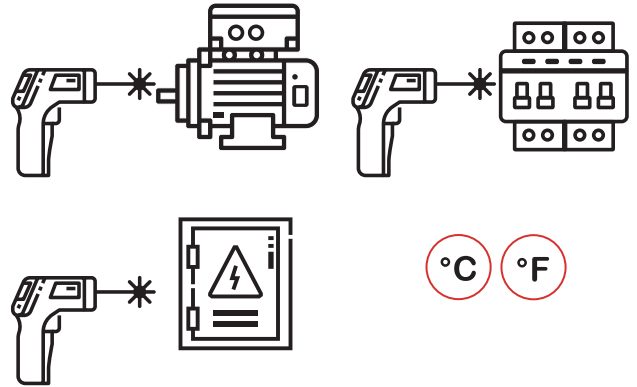

INFRARED THERMOMETER
MS6541

SKU NO.: MS6541CBGLO
UPC CODE: 810053674291
EAN CODE: 8435394779362

FEATURE

- Color Display.
- Auto Power Off.
- Spectral Response 8-14 μm.
- Laser <1mW/630-670nm.

SPECIFICATIONS

IRT Temperature -50°C~760°C/-58°F~1400°F	Repeatability ±0.1°C
K-Type Temperature -50°C~300°C/-58°F~572°F	Emissivity 0.10~1.00

CONTENTS

- 192x95x83mm
7.5"x3.7"x3.3"
275g/0.6lb
- 1x9V 6F22 Battery
- K type thermocouple
Carry bag
Battery
- Calibration Certificate
- Quick Start Guide

PACKAGING INFORMATION

- Color Box**
L126xW58xH210mm
- Carton Box**
44.5x34x28cm
- X 20PCS**

ENVIRONMENTAL METERS

SOUND LEVEL METER | ANEMOMETER | LIGHT METER
MOISTURE TESTER | TACHOMETERS | GAS DETECTOR
MULTI-FUNCTIONS ENVIRONMENT TESTER | DISTANCE METERS
ELECTRONIC STUD METAL FINDER | VOLTAGE AND CURRENT
CALIBRATOR





MAIN APPLICATIONS

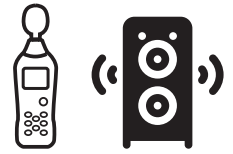
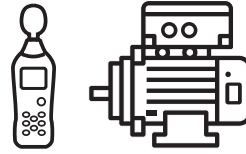

DIGITAL SOUND LEVEL METER
MS6700

SKU NO.: MS6700CBGLO
UPC CODE: 810053676691
EAN CODE: 8435394784779

FEATURE

- Auto & Manual Ranging.
- Auto Power Off.
- Dynamic 50dB.
- Frequency 31.5Hz~8kHz.

SPECIFICATIONS

Sound Level 30dB~130dB	Frequency 31.5Hz~8KHz	Dynamic 50dB
Display Counts 2000		

CONTENTS



265x80x69mm
10.4"x3.15"x2.7"
317g/0.7lb



6x1.5V AAA
Batteries



ACCESSORIES

Windscreen
Earphone plug
Wapping case
Battery



Calibration
Certificate



Quick Start
Guide

PACKAGING INFORMATION



Color Box
L160xW74xH295mm



Carton Box
38.5x32x34cm



X 10PCS



MAIN APPLICATIONS

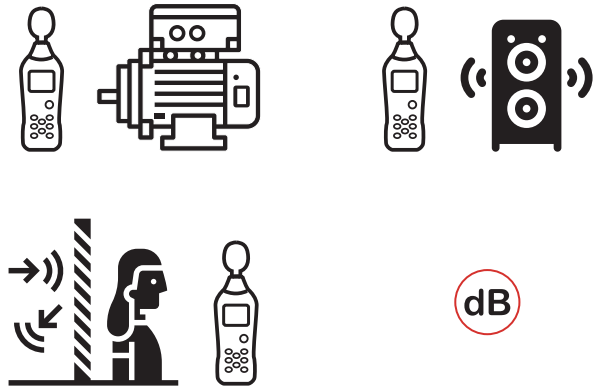

DIGITAL SOUND LEVEL METER
MS6701

SKU NO.: MS6701CBGLO
UPC CODE: 810053674321
EAN CODE: 8435394779393

FEATURE

- Auto & Manual Ranging.
- Auto Power Off.
- Dynamic 50dB.
- Frequency 31.5Hz~8kHz.

SPECIFICATIONS

Sound Level 30dB~130dB	Frequency 31.5Hz~8KHz	Dynamic 50dB
Data Recording 16000	Display Counts 2000	

CONTENTS

- 265x80x69mm
10.4"x3.15"x2.7"
317g/0.7lb
- 6x1.5V AAA Batteries
- Windscreen
- Earphone plug
- Wapping case
- USB Interface cable
- Software CD
- Battery
- Calibration Certificate
- Quick Start Guide

PACKAGING INFORMATION

- Color Box**
L160xW74xH295mm
- Carton Box**
38.5x32x34cm
- X 10PCS**



MAIN APPLICATIONS

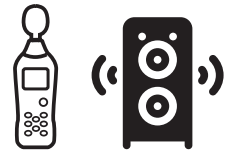
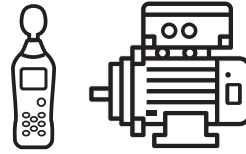

DIGITAL SOUND LEVEL METER
MS6708

SKU NO.: MS6708CBGLO
UPC CODE: 810053674338
EAN CODE: 8435394779409

FEATURE

- Auto & Manual Ranging.
- Auto Power Off.
- Dynamic 50dB.
- Loudness Measurement..

SPECIFICATIONS

Sound Level
30dB~130dB

Frequency
10Hz~8kHz

Dynamic
50dB

Display Counts
2000

CONTENTS



193×60×29mm
7.6"×2.4"×1.1"
222g/0.48lb



4×1.5V AAA
Batteries



ACCESSORIES

Windscreen
Carry bag
Battery



Calibration
Certificate



Quick Start
Guide

PACKAGING INFORMATION



Color Box
L95×W45×H230mm



Carton Box
49.5×27×41cm



X 40PCS



MAIN APPLICATIONS

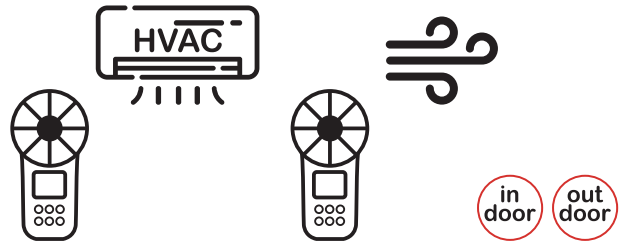

CONTENTS

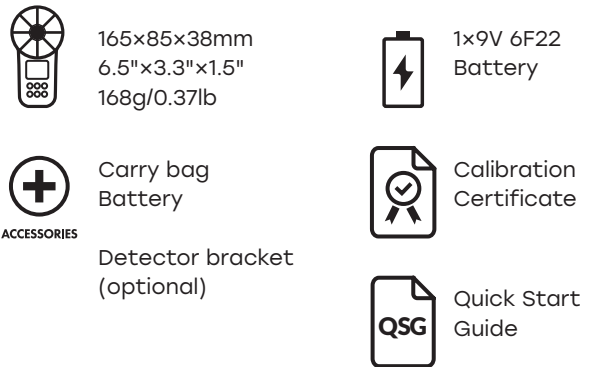

DIGITAL ANEMOMETER

MS6252A

SKU NO.: MS6252ACBGLO
 UPC CODE: 810053672181
 EAN CODE: 8435394777900

FEATURE

- Display 9999 Counts With Backlight.
- Flow Area Setting.
- MAX/MIN.
- Data Hold.

SPECIFICATIONS

m/s 0.80~40.00m/s	km/h 2.88~144.0km/h	ft/s 2.62~131.2ft/s
Knots 1.6~77.70knots	mile/h 1.8~90.00mil/h	ft/m 157.5~7874ft/m
Display Counts 9999		

PACKAGING INFORMATION

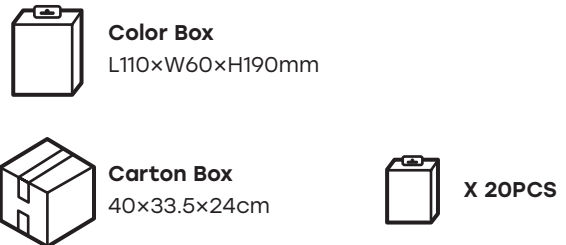



DIGITAL ANEMOMETER
MS6252B

SKU NO.: MS6252BCBGLO
UPC CODE: 810053673096
EAN CODE: 8435394778822

FEATURE

- USB Interface.
- Display 9999 Counts With Backlight.
- Temperature Mode.
- MAX/MIN/Data Hold.

SPECIFICATIONS

m/s 0.80~40.00m/s	km/h 2.88~144.0km/h	ft/s 2.62~131.2ft/s
Knots 1.6~77.7knots	mile/h 1.8~90.00mil/h	ft/m 157.5~7874ft/m
Temperature -10°C~60°C/14°F~140°F		Display Counts 9999

MAIN APPLICATIONS

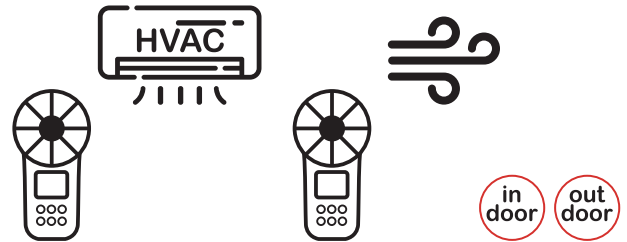

CONTENTS

	165×85×38mm 6.5"×3.3"×1.5" 168g/0.37lb		1×9V 6F22 Battery
	Carry bag Battery USB interface cable Software CD		Calibration Certificate
	Detector bracket (optional)		Quick Start Guide

PACKAGING INFORMATION

	Color Box L110×W60×H190mm	
	Carton Box 40×33.5×24cm	X 20PCS



MAIN APPLICATIONS

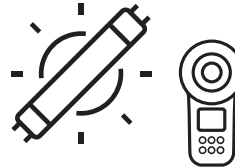
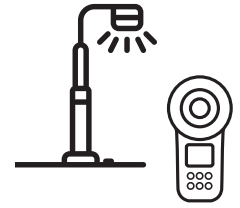
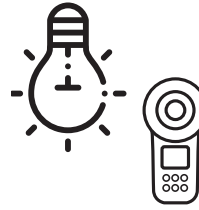

DIGITAL LIGHTMETER [LUX]
MS6610

SKU NO.: MS6610CBGLO
UPC CODE: 810053673058
EAN CODE: 8435394778785

FEATURE

- Data Hold.
- Silicon Photo Diode with Filter Photo Detector.
- Lead Length 150cm (Approx).
- Low Battery Indicator.

SPECIFICATIONS

LUX Ranging
50,000

Display Counts
2000

CONTENTS



126×72×27mm
5.0"×2.8"×1.0"
180g/0.4lb

Detector Size:
83×52×21mm
3.2"×2.0"×0.8"



ACCESSORIES

Carry bag
Battery



1×9V 6F22
Battery



Calibration
Certificate



Quick Start
Guide

PACKAGING INFORMATION



Color Box
L115×W55×H165mm



Carton Box
48×34×31.5cm



X 40PCS



MAIN APPLICATIONS

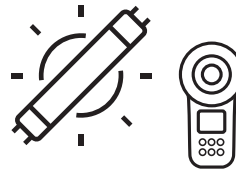
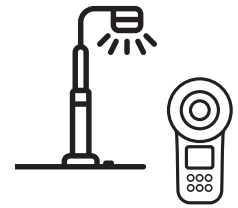
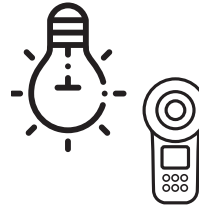

**DIGITAL LIGHTMETER [LUX/FC]
MS6612**

SKU NO.: MS6612CBGLO
UPC CODE: 810053674307
EAN CODE: 8435394779379

FEATURE

- Relative Measurement.
- Peak Measurement.
- Zero Calibration.
- LUX & FC unit selection.

SPECIFICATIONS

LUX Ranging 200,000	FC Ranging 20,000	Display Counts 2000
-------------------------------	-----------------------------	-------------------------------

CONTENTS



170×89×43mm
6.7"×3.5"×1.7"
420g/0.93lb



1×9V 6F22
Battery



ACCESSORIES

Carry bag
Battery



Calibration
Certificate



Quick Start
Guide

PACKAGING INFORMATION



Color Box
L110×W60×H190mm



Carton Box
40×33.5×24cm



X 20PCS



MAIN APPLICATIONS

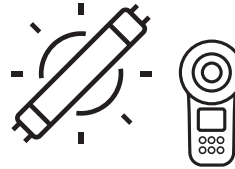
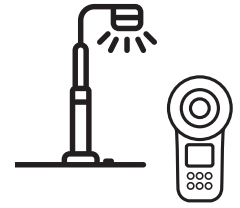
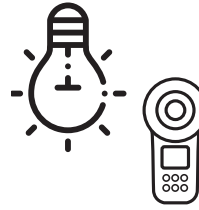

**DIGITAL LIGHTMETER [LUX/FC/CD]
MS6612B**

SKU NO.: MS6612BCBGLO
UPC CODE: 810053674314
EAN CODE: 8435394779386

FEATURE

- Relative Measurement.
- Peak Measurement.
- Zero Calibration.
- LUX, FC & CD unit selection.

SPECIFICATIONS

CD Ranging 999,900	LUX Ranging 200,000	FC Ranging 20,000
Display Counts 2000		

CONTENTS



170×89×43mm
6.7"×3.5"×1.7"
420g/0.93lb



1×9V 6F22
Battery



ACCESSORIES

Carry bag
Battery



Calibration
Certificate



Quick Start
Guide

PACKAGING INFORMATION



Color Box
L110×W60×H190mm



Carton Box
40×33.5×24cm



X 20PCS



MAIN APPLICATIONS

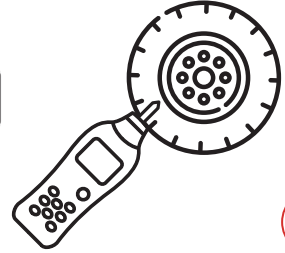
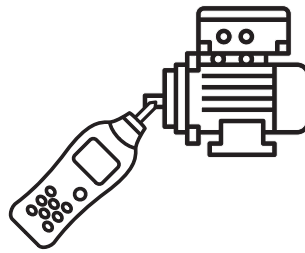

CONTENTS



170×60×27mm
6.7"×2.4"×1.1"
130g/0.28lb



4×1.5AAA
Batteries



ACCESSORIES

Measurement idler wheels
Touch tips
Lengthening bar
Carry bag
Battery



Calibration Certificate



Quick Start Guide

DIGITAL TACHOMETER (Contact)
MS6208A

SKU NO.: MS6208ACBGLO
UPC CODE: 810053672167
EAN CODE: 8435394777887

FEATURE

- Contact Measuring Mode.
- Unit Selection m/min, m/sec, ft/min, ft/sec, in/min
- Auto Power Off.

SPECIFICATIONS

Ranging (contact)
50~19,999RPM

PACKAGING INFORMATION



Color Box
L95×W45×H195mm



Carton Box
41.5×27×41cm







X 40PCS

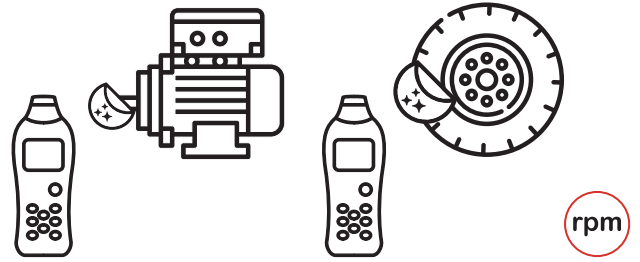

MAIN APPLICATIONS



CONTENTS

-  155×60×27mm
6.1"×2.4"×1.1"
120g/0.26lb
-  4×1.5 AAA Batteries
-  Reflective sheetin
Carry bag
Battery
-  Calibration Certificate
-  Quick Start Guide

DIGITAL TACHOMETER (Non-Contact)
MS6208B

SKU NO.: MS6208BCBGLO
UPC CODE: 810053672174
EAN CODE: 8435394777894



FEATURE

- Non-Contact Measuring Mode.
- Measuring Distance 50mm~250mm.
- Auto Power Off.
- MAX/MIN.

SPECIFICATIONS

Ranging (non-contact)
50~99,999 RPM

PACKAGING INFORMATION

-  **Color Box**
L95×W45×H195mm
-  **Carton Box**
41.5×27×41cm
-  **X 40PCS**



MAIN APPLICATIONS

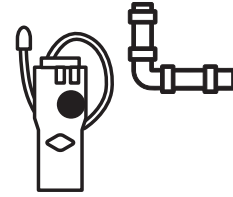
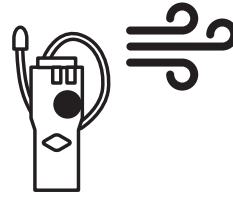

CONTENTS



172×70×465mm
6.8"×2.8"×1.8"
354g/0.78lb



4×1.5 AA
Batteries



Carry bag
Battery



Calibration
Certificate

ACCESSORIES



Quick Start
Guide

COMBUSTIBLE GAS DETECTOR

MS6310

SKU NO.: MS6310CBGLO
UPC CODE: 810053672334
EAN CODE: 8435394778242

FEATURE

- Easy to Identify and Pinpoint Gas Leaks.
- Portable and High Sensitivity.
- Resume Original Measurement State After 7~10 Minutes in Clear Air.

SPECIFICATIONS

Resolution
50ppm

Alarm
10%~40%

PACKAGING INFORMATION



Color Box
L130×W63×H255mm



Carton Box
53×34×28.5mm



X 20PCS



MAIN APPLICATIONS

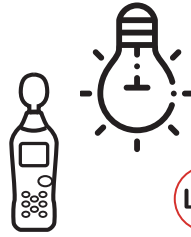

Lux

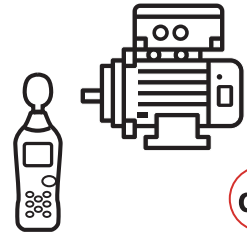

dB



km/h

knots

m/s

FPM

MULTI-FUNCTIONS ENVIRONMENT TESTER
MS6300

SKU NO.: MS6300CBGLO
UPC CODE: 810053672594
EAN CODE: 8435394778235

FEATURE

- AVG / MAX / MIN / DIF (MAX-MIN)
- A/C Weighting Indication.
- Data Hold.
- Display Backlight.

SPECIFICATIONS

Sound Level 30~130dB(A)	Luminance 0~50,000LUX	Wind Speed 0.5~20m/s
Air Flow 999,900CMM/CFM	Humidity 20~80%RH	
Temperature -10°C~60°C/14°F~140°F		

CONTENTS



280×89×50mm
11.0"×3.5"×2.0"
433g/0.95lb



1×9V 6F22
Battery



ACCESSORIES

Windbreak
Holder
Wrapping case
Battery



Calibration
Certificate



Quick Start
Guide

PACKAGING INFORMATION



Color Box
L325×W80×H160mm



Carton Box
42×35×35cm



X 10PCS



MAIN APPLICATIONS

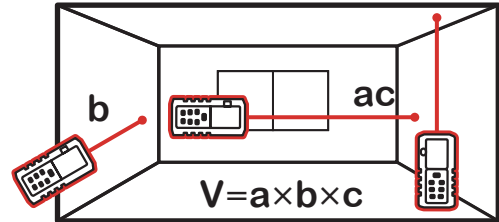
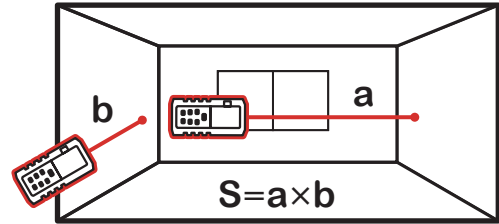

DISTANCE METER

MS6404/06/08

SKU NO.	MS6404CBGLO	MS6406CBGLO	MS6408CBGLO
UPC CODE	810053674246	810053676837	810053676844
EAN CODE	8435394779317	8435394786209	8435394786216

FEATURE

- Automatically cut off laser 20s.
- Automatic shutdown 150s.
- Data Logging 30 groups.
- MIN & MAX measurement.

SPECIFICATIONS

Distance(MS6404)	Distance(MS6406)	Distance(MS6408)
40m	60m	80m
Accuracy	Unit	
±2.0mm	mm / inch / ft	

CONTENTS



112×52×27mm
4.4"×6.0".0×1"
120g/0.26lb



2×1.5V AAA
Batteries



Portable bag
Battery

ACCESSORIES



Calibration
Certificate



Quick Start
Guide

PACKAGING INFORMATION



Color-Box
L75×W55×H155mm



Carton Box
61×33×25cm



X 60PCS



MAIN APPLICATIONS

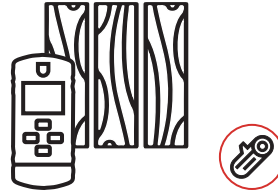

CONTENTS



160×74×42mm
6.3"×2.9"×1.65"
154g/0.33lb



1×9V 6F22
Battery



Battery

ACCESSORIES



Calibration
Certificate



Quick Start
Guide

ELECTRONIC STUD METAL FINDER

MS6906

SKU NO.: MS6906CBGLO
UPC CODE: 810053674574
EAN CODE: 8435394779645

FEATURE

- Auto Power Off.
- Low Battery Display.
- Display Backlight, Work Light.

SPECIFICATIONS

Wooden Pillar
30mm

Metal Stud Detection Depth
30mm

Metal Pipe Detector Depth
50mm

AC Voltage Detector Depth(50~600VAC)
75mm

PACKAGING INFORMATION



Color Box
L145×W60×H188mm



Carton Box
40×32×31.5cm



X 20PCS



MAIN APPLICATIONS

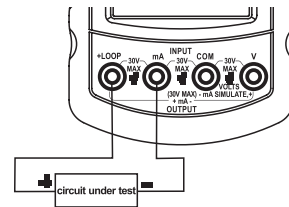
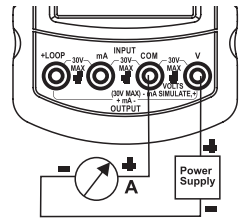
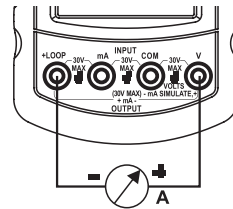
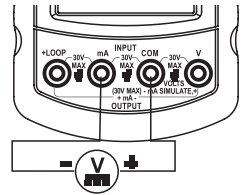
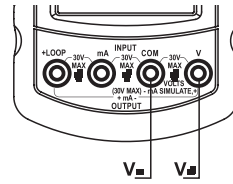

VOLTAGE AND CURRENT CALIBRATOR
MS7221

SKU NO.: MS7221CBGLO
UPC CODE: 810053672020
EAN CODE: 8435394777757

FEATURE

- Selection of Absolute or Percentage Value in Amp Mode
- Calibration and Simulation of External Transducers
- LOOP Mode

SPECIFICATIONS

DC Voltage (Input/Output)
0~100mV, 0~10V

DC Current
0~24mA

DC Voltage (Loop)
0~24V

CONTENTS



190×89×42mm
7.5"×3.5"×1.7"
350g/0.77lb



1×9V 6LR61
Battery



ACCESSORIES

Test leads
Wapping case
Battery



Calibration
Certificate



Quick Start
Guide

PACKAGING INFORMATION



Color Box
L188×W88×H264mm



Carton Box
47×31×39.5cm



X 10PCS

TEST LEADS

T3009U



SKU NO..	UPC CODE	EAN CODE
T3009UPEGLO		
- Probe Length: 146mm/ø10.2mm Right Angle Type, M4 screw - Length: 1200mm - Tip: ø2mm		- Plug: ø4.5mm - Wire: UL 1803/18AWG - MAX 10A

TEST LEADS

T3030U



SKU NO..	UPC CODE	EAN CODE
T3030UPEGLO	810053672778	8435394778419
- Probe Length: 143mm/ø10mm - Length: 1000mm - Tip: ø2mm		- Plug: ø4.5mm - Wire: UL 1803/18AWG - MAX 10A

TEST LEADS

T3016U



SKU NO..	UPC CODE	EAN CODE
T3016UPEGLO	810053674000	8435394779072
- Probe Length: 132mm/ø10mm Right Angle Type, M4 screw - Length: 1000mm - Tip: ø2mm		- Plug: ø4.5mm - Wire: UL 1803/18AWG - MAX 10A

TEST LEADS

T3033U

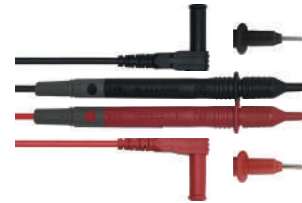

SKU NO..	UPC CODE	EAN CODE
T3033UPEGLO	810053672785	8435394778426
- Probe Length: 119mm/ø9mm - Length: 800mm - Tip: ø2mm		- Plug: ø4.5mm - Wire: UL 1803/20AWG - MAX 10A

TEST LEADS

T3022



SKU NO..	UPC CODE	EAN CODE
T3022PEGLO	810053674017	8435394779089
- Straight Type & Right Angle Type - Length: 1000mm - Plug: ø4.5mm		- Wire: UL 1803/18AWG - MAX 10A

TEST LEADS

T3060A



SKU NO..	UPC CODE	EAN CODE
T3060APEGLO	810053674819	8435394783482
- Probe Length: 132mm/ø10mm Right Angle Type, M4 screw - Length: 1000mm - Tip: ø2mm		- Plug: ø4.5mm - Wire: UL 1803/18AWG - MAX 10A

TEST LEADS

T3060B



SKU NO..	UPC CODE	EAN CODE
T3060BPEGLO	810053674826	8435394779881

- Probe Length: 132mm/ø10mm
- Right Angle Type, M4 screw
- Length: 1500mm
- Tip: ø2mm
- Plug: ø4.5mm
- Wire: UL 1803/18AWG
- MAX 10A

TEST LEADS

T3103



SKU NO..	UPC CODE	EAN CODE
T3103PEGLO	810053674024	8435394779096

- Straight Type
- Length: 1340mm
- Plug: ø4.5mm
- Wire: UL 1803/18AWG
- MAX 10A

Big Mouth Alligator Clip

C3107



SKU NO..	UPC CODE	EAN CODE
C3107PEGLO	810053674031	8435394779102

- Length: 87mm
- ø4mm cross plug
- Max 32A

Alligator Clip

C3109A



SKU NO..	UPC CODE	EAN CODE
C3109APEGLO	810053674901	8435394782355

- Length: 61.5mm
- with M4 screw

Medium Alligator Clip

C3109B



SKU NO..	UPC CODE	EAN CODE
C3109BPEGLO	810053673249	8435394778723

- Length: 55mm
- with M4 screw

IC Test Clip

C3112



SKU NO..	UPC CODE	EAN CODE
C3112PEGLO	810053675014	8435394783451

- Length: 185mm
- Plug: ø4mm Jack
- Max 5A

THERMOCOUPLES
P3400



SKU NO..	UPC CODE	EAN CODE
P3400PEGLO	810053676752	8435394779867

- Length:1000mm
- Ranging:-40~260°C(-40~500°F)

THERMOCOUPLES
P3408A



SKU NO..	UPC CODE	EAN CODE
P3408APEGLO	810053675410	8435394783482

- Length:1000mm
- Ranging:-40~260°C(-40~500°F)
- Plug lenth : 12mm

THERMOCOUPLES
P3401



SKU NO..	UPC CODE	EAN CODE
P3401PEGLO	810053674888	8435394782096

- Length:1000mm
- Ranging:-40~260°C(-40~500°F)

THERMOCOUPLES
P3409A



SKU NO..	UPC CODE	EAN CODE
P3409APEGLO	810053675434	8435394783505

- Length:1000mm
- Ranging:-40~800°C(-40~1472°F)
- Plug lenth : 12mm

THERMOCOUPLES
P3408B



SKU NO..	UPC CODE	EAN CODE
P3408BPEGLO	810053675427	8435394783499

- Length:1000mm
- Ranging:-40~260°C(-40~500°F)
- Plug lenth : 16mm

THERMOCOUPLES
P3409B



SKU NO..	UPC CODE	EAN CODE
P3409BPEGLO	810053674802	8435394779867

- Length:1000mm
- Ranging:-40~800°C(-40~1472°F)
- Plug lenth : 16mm

THERMOCOUPLES

P3410



SKU NO..	UPC CODE	EAN CODE
P3410PEGLO	810053675441	8435394783512

- Length:1000mm
 - Ranging:-40~600°C(-40~1112°F)

THERMOCOUPLES

P3412



SKU NO..	UPC CODE	EAN CODE
P3412PEGLO	810053675458	8435394783529

- Length:1000mm
 - Ranging:-40~260°C(-40~500°F)

MASTECH®

www.mastech-group.com



AMERICAS

MGL America, Inc.

✉ cs.na@mgl-intl.com

6509 Northpark Blvd Unit 400,
Charlotte, NC 28216 USA
Tel: +1 833 533-5899

APAC

MGL APPA Corporation

✉ cs.apac@mgl-intl.com

Flat 4-1, 4/F, No. 35, Section 3
Minqun East Road, Taipei, Taiwan
Tel: +886 2-2508-0877

EMEA

MGL Euman S.L.

✉ cs.emea@mgl-intl.com

C/ Picu Castiellu, Parcelas i1-i4
Argame, Morcin 33163, Asturias, Spain
Tel: +36 985-08-18-70

MEXICO & LATAM

MGL LATAM SA DE CV

✉ cs.latam@mgl-intl.com

Colonia Industrial Vallejo Del.
Azcapotzalco 02300, Mexico DF
Tel: +1 883-533-5899

UNITED KINGDOM

POWER PROBE GROUP LIMITED

✉ cs.uk@mgl-intl.com

14 Weller St, London, SE1 1QU, UK
Tel: +34 985-08-18-70